

LSTA24 and MSTA24 FIELD-FORMED AS A STUD-TO-MUDSILL ANCHOR

MATERIAL: LSTA24 – 20 gauge
MSTA24 – 18 gauge

FINISH: Galvanized; check with factory for additional corrosion protection.

INSTALLATION:

- Slide the LSTA or MSTA strap underneath the mudsill with 10¼” of the strap protruding out from the inside of the 2x4 mudsill.
- If a 2x6 mudsill is used, only 9¼” of the strap should protrude out from the inside of the sill.
- **Each bend in the strap must be tight and the strap must sit flush against the edge of the mudsill and the stud or sheathing.**
- Bend strap one time only.

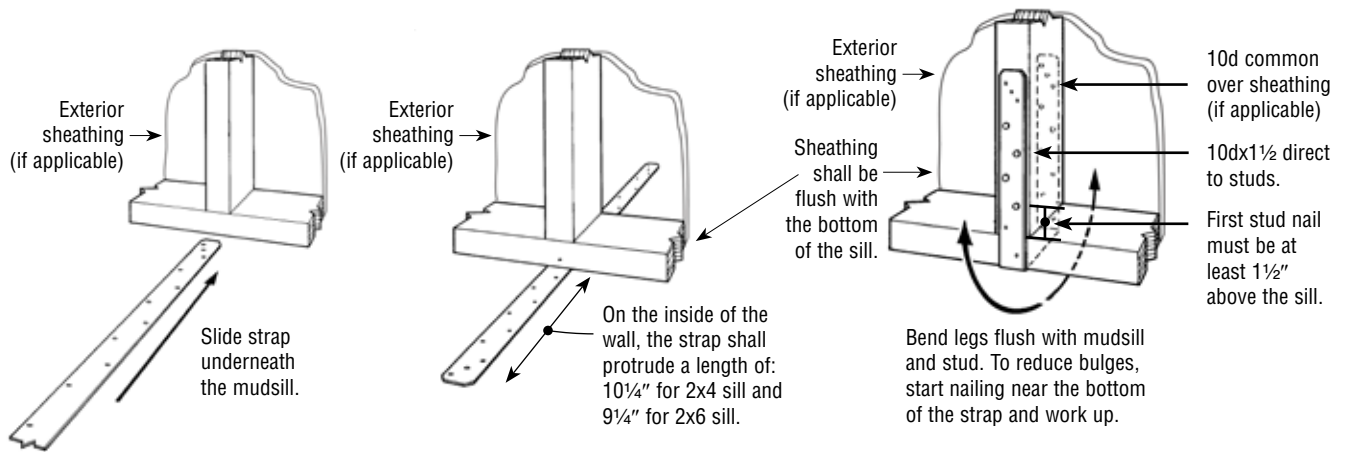

Available with additional corrosion protection.

Model No.	Fasteners			Allowable Uplift Loads					
	Total Quantity (half on each side)	Direct to Stud	Over Sheathing	DFL		SP		SPF	
				(133)	(160)	(133)	(160)	(133)	(160)
LSTA24	6	10dx1½	10d	930	1110	1010	1205	800	950
LSTA24	8	10dx1½	10d	1235	1235	1235	1235	1065	1235
MSTA24	8	10dx1½	10d	1270	1505	1380	1630	1090	1290
MSTA24	10	10dx1½	10d	1590	1640	1640	1640	1365	1615

1. Allowable loads have been increased 33% and 60% for earthquake or wind loading; no further increase allowed. Reduce where other loads govern.

This technical bulletin is effective until January 31, 2010, and reflects information available as of December 1, 2007. This information is updated periodically and should not be relied upon after January 31, 2010; contact Simpson for current information and limited warranty or see www.strongtie.com.

Home Office
5956 W. Las Positas Blvd.
Pleasanton, CA 94588
FAX: 925/847-1603

Southwest U.S.A.
260 N. Palm Street
Brea, CA 92821
FAX: 714/871-9167

Southeast U.S.A.
2221 Country Lane
McKinney, TX 75069
FAX: 972/542-5379

Western Canada
11476 Kingston St.
Maple Ridge, BC V2X 0Y5
FAX: 604/465-0297

Northwest U.S.A.
5151 S. Airport Way
Stockton, CA 95206
FAX: 209/234-3868

Northeast U.S.A.
2600 International Street
Columbus, OH 43228
FAX: 614/876-0636

Eastern Canada
5 Kenview Blvd.
Brampton, ON L6T 5G5
FAX: 905/458-7274

Warehouses & Manufacturing:
Eagan, MN; Enfield, CT; Gallatin, TN;
High Point, NC; Jacksonville, FL;
Kent, WA; Langley, BC

800-999-5099
www.strongtie.com

© 2008 Simpson Strong-Tie Company Inc.
Printed in the U.S.A.

T-STRAPS07 12/07 exp. 1/10