

ESR-2105

Used for Florida State Wide Product Approval #

FL10852

Products on this Report which are approved:

Product	FL#	Product	FL#	Product	FL#
CMST12	10852.1	LSTA21	10852.4	MSTA30Z	10852.9
CMST14	10852.1	LSTA24	10852.4	MSTA36	10852.9
CMSTC16	10852.1	LSTA30	10852.4	MSTA36Z	10852.9
CS16	10852.1	LSTA36	10852.5	MSTA9	10852.10
CS16-R	10852.1	LSTI49	10852.6	MSTC28	10852.11
CS16Z	10852.1	LSTI73	10852.6	MSTC40	10852.11
CS18	10852.1	MST27	10852.7	MSTC52	10852.11
CS18-R	10852.1	MST27HDG	10852.7	MSTC66	10852.11
CS18S	10852.1	MST37	10852.7	MSTC78	10852.11
CS20	10852.1	MST37HDG	10852.7	MSTI26	10852.12
CS20-R	10852.1	MST48	10852.7	MSTI36	10852.12
CS22	10852.1	MST48HDG	10852.7	MSTI48	10852.12
CS22-R	10852.1	MST60	10852.7	MSTI60	10852.12
FHA12	10852.2	MST60HDG	10852.7	MSTI72	10852.12
FHA18	10852.2	MST72	10852.7	ST12	10852.13
FHA24	10852.2	MSTA12	10852.8	ST18	10852.13
FHA30	10852.2	MSTA12Z	10852.8	ST2115	10852.14
FHA6	10852.2	MSTA15	10852.8	ST2122	10852.13
FHA9	10852.2	MSTA15Z	10852.8	ST22	10852.13
HST2	10852.3	MSTA18	10852.9	ST2215	10852.13
HST3	10852.3	MSTA18Z	10852.9	ST292	10852.13
HST5	10852.3	MSTA21	10852.9	ST6215	10852.13
HST6	10852.3	MSTA21Z	10852.9	ST6224	10852.13
LSTA12	10852.4	MSTA24	10852.9	ST6236	10852.13
LSTA15	10852.4	MSTA24Z	10852.9	ST9	10852.13
LSTA18	10852.4	MSTA30	10852.9		



®

SIMPSON STRONG-TIE COMPANY, INC.

ICC Evaluation Service, Inc.
www.icc-es.org

Business/Regional Office ■ 5360 Workman Mill Road, Whittier, California 90601 ■ (562) 699-0543
Regional Office ■ 900 Montclair Road, Suite A, Birmingham, Alabama 35213 ■ (205) 599-9800
Regional Office ■ 4051 West Flossmoor Road, Country Club Hills, Illinois 60478 ■ (708) 799-2305

DIVISION: 06—WOOD AND PLASTICS
Section: 06090—Wood and Plastic Fastenings

REPORT HOLDER:

SIMPSON STRONG-TIE COMPANY, INC.
5956 WEST LAS POSITAS BOULEVARD
PLEASANTON, CALIFORNIA 94588
(800) 925-5099
www.strongtie.com

EVALUATION SUBJECT:

SIMPSON TIE STRAPS

1.0 EVALUATION SCOPE

Compliance with the following codes:

- 2006 *International Building Code*® (IBC)
- 2006 *International Residential Code*® (IRC)
- Legacy Codes (See Section 8.0)

Property evaluated:

Structural

2.0 USES

The Simpson Strong-Tie FHA, HST, LSTA, LSTI, MST, MSTA, MSTC, MSTI, and ST Series Straight Tie Straps; and CMST and CS Series Coiled Tie Straps; and the CMSTC16 Coiled Tie Strap are used to transfer between wood members wind or seismic loads resulting from the critical load combination in accordance with Section 1605.3 of the IBC where allowable stress equations are used. The straps may also be used in structures regulated by the IRC where an engineered design is submitted in accordance with IRC Section R301.1.3.

3.0 DESCRIPTION

3.1 Straight Tie Straps:

The FHA, HST, LSTA, LSTI, MST, MSTA, MSTC, MSTI, and ST Series straight tie straps are supplied in manufacturer-designated lengths with prepunched holes for nails or bolts.

3.1.1 FHA Series: The FHA Series tie straps are $6\frac{3}{8}$ to 30 inches (162 to 762 mm) long, and have a constant width of $1\frac{3}{16}$ inches (30.2 mm). The total strap width between longitudinal edges is $1\frac{7}{16}$ inches (36.5 mm). The longitudinal edges of the tie straps have $\frac{1}{4}$ -inch-deep (6.4 mm) notches that are spaced 2 inches (51 mm) on center. Each end of an FHA strap has four $\frac{11}{64}$ -inch-diameter (4.3 mm) prepunched nail holes. See Figure 1 for a drawing of the FHA Series tie straps. See Table 1A for strap dimensions, fastener schedules, and allowable tension loads based on the IBC.

3.1.2 ST Series: The ST9, ST12, ST18, and ST 22 straps are 9 to $21\frac{5}{8}$ inches (229 to 549 mm) long and $1\frac{1}{4}$ inches (31.8 mm) wide. Each strap has unevenly spaced $\frac{11}{64}$ -inch-diameter (4.3 mm) prepunched nail holes. One end of each strap has a “speed prong” which is formed from the steel strap. See Figure 2 for a drawing of the ST9, ST12, ST18, and ST 22 tie straps.

The ST292, ST2122, ST2215, ST6215, ST6224, and ST6236 straps are $9\frac{5}{16}$ to $33\frac{13}{16}$ inches (236.5 to 858.8 mm) long, and have a constant width of $1\frac{13}{16}$ inches (46 mm). The total strap width between longitudinal edges is $2\frac{1}{16}$ inches (52.4 mm). Notches are $\frac{9}{32}$ inch (7.1 mm) deep and are spaced $1\frac{3}{4}$ inches (44.5 mm) on center. Each longitudinal edge of an ST strap has a row of $\frac{11}{64}$ -inch-diameter (4.3 mm) prepunched nail holes, spaced $1\frac{3}{4}$ inches (44.5 mm) on center. See Figure 3 for a drawing of the ST292, ST2122, ST2215, ST6215, ST6224, and ST6236 tie straps.

The ST2115 strap is $16\frac{5}{16}$ inches (414.3 mm) long and $\frac{3}{4}$ inch (19.1 mm) wide, and has one row of $\frac{11}{64}$ -inch-diameter (4.3 mm), prepunched nail holes, spaced $1\frac{5}{8}$ inches (41.3 mm) on center. See Figure 4 for a drawing of the ST2115 tie strap.

See Table 1A for ST Series tie strap dimensions, fastener schedules, and allowable tension loads based on the IBC.

3.1.3 HST Series: The HST Series tie straps are either $21\frac{1}{4}$ or $25\frac{1}{2}$ inches (540 or 648 mm) long and from $2\frac{1}{2}$ to 6 inches (63.5 to 152 mm) wide. Each end of an HST strap has either three or six prepunched holes to accommodate $\frac{5}{8}$ -inch- or $\frac{3}{4}$ -inch-diameter (15.9 and 19.1 mm) bolts. The spacing and the location of the bolt holes in the strap length comply with the code-required bolt spacing and end distances. See Figure 5 for a drawing of the HST Series tie straps. See Table 2A for strap dimensions, fastener schedules, and allowable tension loads based on the IBC.

3.1.4 MST Series: The MST Series tie straps are 27 to 72 inches (686 to 1829 mm) long and $2\frac{1}{16}$ inches (52.4 mm) wide. Each strap has two rows of $\frac{11}{64}$ -inch-diameter (4.3 mm) prepunched nail holes spaced $1\frac{3}{4}$ inches (43.7 mm) on center. Additionally, the straps have $\frac{5}{8}$ -inch-diameter (15.9 mm) prepunched bolt holes spaced $5\frac{1}{4}$ inches (133.4 mm) on center. See Figure 6 for a drawing of the MST Series tie straps. See Table 2A for strap dimensions, fastener schedules, and allowable tension loads based on the IBC.

3.1.5 LSTA and MSTA Series: The LSTA and MSTA Series tie straps are 9 to 36 inches (229 to 914 mm) long and $1\frac{1}{4}$ inches (32 mm) wide. Each strap has one row of staggered $\frac{11}{64}$ -inch-diameter (4.3 mm) prepunched nail holes. Longitudinal spacing (pitch) of consecutive holes is $1\frac{1}{2}$ inches (38 mm), and the transverse distance (gage) between staggered holes is $\frac{9}{16}$ inch (14.3 mm). Both ends of every strap has one nail hole located between the last two staggered holes. See Figure 7 for a drawing of the LSTA and

***Corrected October 2007 and December 2007**

ES REPORTS™ are not to be construed as representing aesthetics or any other attributes not specifically addressed, nor are they to be construed as an endorsement of the subject of the report or a recommendation for its use. There is no warranty by ICC Evaluation Service, Inc., express or implied, as to any finding or other matter in this report, or as to any product covered by the report.



MSTA Series tie straps. See Table 3A for strap dimensions, fastener schedules, and allowable tension loads based on the IBC.

3.1.6 LSTI Series: The LSTI Series tie straps are either 49 or 73 inches (1244 or 1854 mm) long and $3\frac{3}{4}$ inches (95.3 mm) wide. Each strap has two rows of staggered $\frac{5}{32}$ -inch-diameter (4.0 mm) prepunched nail holes. Longitudinal spacing (pitch) of consecutive holes in a row is 3 inches (76 mm), and the transverse distance (gauge) between staggered holes in a row is $\frac{3}{8}$ inch (9.5 mm). See Figure 8 for a drawing of the LSTI Series tie straps. See Table 3A for strap dimensions, fastener schedules, and allowable tension loads based on the IBC.

3.1.7 MSTI Series: The MSTI Series tie straps are $2\frac{1}{16}$ inches (52.4 mm) wide and from 26 to 72 inches (660 to 1829 mm) long. Each strap has three rows of $\frac{5}{32}$ -inch-diameter (4.0 mm) prepunched nail holes spaced 3 inches (76 mm) on center. The holes in adjacent rows are offset by 1 inch (25.4 mm), resulting in one nail hole per inch of strap. See Figure 9 for a drawing of the MSTI Series tie straps. See Table 3A for strap dimensions, fastener schedules, and allowable tension loads based on the IBC.

3.1.8 MSTC Series: The MSTC Series tie straps are $28\frac{1}{4}$ to $77\frac{3}{4}$ inches (718 to 1975 mm) long and 3 inches (76.2 mm) wide. The straps have two rows of staggered prepunched holes spaced $1\frac{1}{2}$ inches (38.1 mm), measured from center-to-center of holes. On the nail head side of the strap, the holes are oblong and measure $\frac{13}{64}$ inch wide by $\frac{9}{32}$ inch long (5.1 mm by 7.1 mm), and are chamfered at 120 degrees. On the wood side of the strap, the holes are $\frac{11}{64}$ inch wide by $\frac{1}{4}$ inch long (4.4 mm by 6.4 mm). The long direction of the nail holes is perpendicular to the length of the strap. See Figure 10 for a drawing of the MSTC Series tie straps. See Table 3A for strap dimensions, fastener schedules, and allowable tension loads based on the IBC.

3.2 Coiled Tie Straps:

The CS Series, CMST Series, and CMSTC16 tie straps are supplied in coils and are cut to a specified length at the jobsite for engineered applications where the connected wood members are not abutting each other.

3.2.1 CS Series: The CS14, CS16, CS18, CS20, and CS22 straps are supplied as 100-, 150-, 200-, 250-, and 300-foot-long (30.5, 45.7, 61.0, 76.2, and 91.4 m) coils, respectively. The coiled steel is $1\frac{1}{4}$ inches (32 mm) wide and has two rows of prepunched, $\frac{5}{32}$ -inch-diameter (4.0 mm) holes. The longitudinal spacing of the holes in each row is $2\frac{1}{16}$ inches (52.4 mm). See Figure 11 for a drawing of the CS Series tie straps and Figure 14 for a typical installation. See Table 4A for strap dimensions, fastener schedules, and allowable tension loads based on the IBC.

3.2.2 CMST Series: The CMST12 strap is supplied as a 40-foot-long (12.19 m) coil, and the CMST14 strap is supplied as a $52\frac{1}{2}$ -foot-long (16.0 m) coil. The coiled steel is 3 inches (76 mm) wide and has two rows of prepunched round holes with $\frac{11}{64}$ -inch (4.3 mm) diameters, and two rows of equilateral triangular holes sized to circumscribe an $\frac{11}{64}$ -inch-diameter (4.3 mm) hole. The longitudinal spacing of the round and triangular holes in each row is 3.5 inches (88.9 mm). See Figure 12 for a drawing of the CMST14 tie strap, and Figure 13 for a typical installation. See Table 4A for strap dimensions, fastener schedules, and allowable tension loads based on the IBC.

3.2.3 CMSTC16: The CMSTC16 strap is supplied as a 54-foot-long (16.46 m) coil. The width of the coiled steel is 3 inches (76.2 mm). The strap has two rows of staggered prepunched holes spaced $1\frac{1}{2}$ inches (38.1 mm), measured from center-to-center of holes. On the nail head side of the

strap, the holes are oblong and measure $\frac{1}{4}$ inch wide by $2\frac{1}{64}$ inch long (6.4 mm by 8.3 mm), and are chamfered at 120 degrees. On the wood side of the strap, the holes are $\frac{11}{64}$ inch wide by $\frac{1}{4}$ inch long (4.4 mm by 6.4 mm). See Figure 13 for a drawing of the CMSTC16 tie strap and Figure 13 for a typical installation. See Table 4A for strap dimensions, fastener schedules, and allowable tension loads based on the IBC.

3.3 Materials:

3.3.1 Steel: The tie straps described in this report are manufactured from galvanized steel complying with ASTM A 653, SS designation, and minimum G90 zinc coating specifications, except for the HST3 and HST6 tie straps, which are manufactured from galvanized steel complying with ASTM A 1011. Refer to the tables in this report for the minimum specified yield and tensile strengths, F_y and F_u , respectively, of the steel for each strap described in this report. Some models are available with a G185 continuous sheet galvanization in accordance with ASTM A 653. The model numbers of tie straps with a G185 zinc coating are followed by the letter Z. Some models are available with a batch hot-dip galvanized coating with a minimum specified coating weight of 2.0 ounces of zinc per square foot of surface area (600 g/m²), total for both sides, in accordance with ASTM A 123. The model numbers of tie straps with a batch hot-dipped zinc coating are followed by the letters HDG.

The galvanized steel tie straps have the following minimum base-metal thicknesses:

GAGE	BASE-METAL THICKNESS (inch)
No. 3	0.2285
No. 7	0.1715
No. 10	0.1275
No. 12	0.0975
No. 14	0.0685
No. 16	0.0555
No. 18	0.0445
No. 20	0.0334

3.3.2 Wood: Wood members with which the tie straps are used must be either sawn lumber or engineered lumber having a minimum specific gravity of 0.50 (minimum equivalent specific gravity of 0.50 for engineered lumber), and having a maximum moisture content of 19 percent (16 percent for engineered lumber). The thickness (depth) of the wood main member must be equal to or greater than the length of the fasteners specified in the tables in this report, unless the reduced penetration effect on the load calculation per the applicable National Design Specification for Wood Construction and its Supplement (NDS) is taken into account, or as required by wood member design, whichever is greater.

3.3.3 Fasteners: Nails must comply with ASTM F 1667 and have minimum bending yield strength, F_{yb} , of 90,000 psi (620.1 MPa). Bolts used with the MST and HST Series tie straps must as a minimum comply with ASTM A 36 or A 307 and have a minimum bending yield strength of 45,000 psi (310.1 MPa).

Fasteners used in contact with preservative-treated or fire-retardant-treated lumber must, as a minimum, comply with IBC Section 2304.9.5 or IRC Section R319.3, as applicable. The lumber treater or report holder should be contacted for recommendations on minimum corrosion resistance and connection capacities of fasteners used with the specific proprietary preservative-treated or fire-retardant-treated lumber.

4.0 DESIGN AND INSTALLATION

4.1 Design:

Tabulated allowable tension loads in this evaluation report are based on allowable stress design and are the lesser of the tie strap steel strength or the connection strength. When connection strength governs, the tabulated allowable loads include the load duration factor, C_D , corresponding to design wind and seismic loads in accordance with the NDS.

Tabulated allowable loads are for tie straps connected to wood used under continuously dry interior conditions, and where sustained temperatures are 100°F (37.8°C) or less.

When tie straps are fastened to wood having a moisture content greater than 19 percent (16 percent for engineered wood products), or where wet service is expected, the allowable tension loads based on fastener lateral design values in this evaluation report must be adjusted by the wet service factor, $C_{M,w}$, specified in the NDS.

When tie straps are connected to wood that will experience sustained exposure to temperatures exceeding 100°F (37.7°C), the allowable loads in this evaluation report must be adjusted by the temperature factor, C_t , specified in the NDS.

Connected wood members must be analyzed for load-carrying capacity at the tie strap connection in accordance with the NDS.

4.2 Installation:

Installation of the tie straps must be in accordance with this evaluation report and the manufacturer's published installation instructions. In the event of a conflict between this report and the manufacturer's published installation instructions, this report governs.

5.0 CONDITIONS OF USE

The Simpson Strong-Tie Straight and Coiled Tie Straps described in this report comply with, or are suitable alternatives to what is specified in, those codes listed in Section 1.0 of this report, subject to the following conditions:

- 5.1 The tie straps must be manufactured, identified, and installed in accordance with this report and the manufacturer's published installation instructions. A copy of the instructions must be available at the jobsite at all times during installation.
- 5.2 Calculations showing compliance with this report must be submitted to the code official. The calculations must be prepared by a registered design professional where required by the statutes of the jurisdiction in which the project is to be constructed.
- 5.3 Adjustment factors noted in Section 4.1 of this report and the applicable codes must be considered, where applicable.
- 5.4 Connected wood members and fasteners must comply, respectively, with Sections 3.3.2 and 3.3.3 of this report.
- 5.5 Use of tie straps with preservative-treated and fire-retardant-treated lumber is outside the scope of this report. Use of fasteners with treated lumber must comply with Section 3.3.3 of this report.

6.0 EVIDENCE SUBMITTED

- 6.1 Structural calculations.
- 6.2 Quality documentation.

7.0 IDENTIFICATION

Each tie strap described in this report is identified with a die-stamped label indicating the name of the manufacturer (Simpson Strong-Tie), the model number, and the number of an index evaluation report (ESR-2523) which contains a

summary of all the product model numbers in the ICC-ES evaluation reports issued to this manufacturer.

8.0 OTHER CODES

8.1 Evaluation Scope:

In addition to the codes referenced in Section 1.0, the products described in this report were evaluated for compliance with the requirements of the following codes:

- 2003 *International Building Code*® (2003 IBC)
- 2003 *International Residential Code*® (2003 IRC)
- 2000 *International Building Code*® (2000 IBC)
- 2000 *International Residential Code*® (2000 IRC)
- 1997 *Uniform Building Code*™ (UBC)

Simpson Strong-Tie FHA, HST, LSTA, LSTI, MST, MSTA, MSTC, MSTI, and ST Series Straight Tie Straps; and CMST and CS Series Coiled Tie Straps; and the CMSTC16 Coiled Tie Strap described in this report comply with, or are suitable alternatives to what is specified in, the codes listed above, subject to the provisions of Sections 8.2 through 8.7.

8.2 Uses:

8.2.1 2003 IBC, 2003 IRC, 2000 IBC, and 2000 IRC: The same as Section 2.0 of this report.

8.2.2 UBC: The Simpson Strong-Tie FHA, HST, LSTA, LSTI, MST, MSTA, MSTC, MSTI, and ST-Series Straight Tie Straps; and CMST and CS Series Coiled Tie Straps; and the CMSTC16 Coiled Tie Strap are used to transfer between wood members wind or seismic loads resulting from the critical basic load combination in accordance with Section 1612.3 of the UBC.

8.3 Description:

8.3.1 2003 IBC and 2003 IRC:

8.3.1.1 Straight Tie Straps: The same as Sections 3.1.1 through 3.1.8 of this report.

8.3.1.2 Coiled Tie Straps: The same as Sections 3.2.1 through 3.2.3 of this report.

8.3.1.3 Materials: The same as Sections 3.3.1 through 3.3.4 of this report.

8.3.2 2000 IBC, 2000 IRC, and UBC:

8.3.2.1 Straight Tie Straps: The same as Sections 3.1.1 through 3.1.8 of this report, with the following modifications:

- See Table 1B for FHA and ST Series tie strap dimensions, fastener schedules, and allowable tension loads based on the IBC and UBC.
- See Table 2B for HST and MST Series tie strap dimensions, fastener schedules, and allowable tension loads based on the IBC and UBC.
- See Table 3B for LSTA, MSTA, LSTI, MSTC and MSTI Series tie strap dimensions, fastener schedules, and allowable tension loads based on the IBC and UBC.

8.3.2.2 Coiled Tie Straps: The same as Sections 3.2.1 through 3.2.3 of this report, with the following modification: See Table 4B for the CS and CMST Series and the CMSTC16 tie strap dimensions, fastener schedules, and allowable tension loads based on the IBC and UBC.

8.3.2.3 Materials: The same as Sections 3.1.1 through 3.1.4 of this report, except for the following modification: Replace the first sentence of the second paragraph of Section 3.3.3 (Fasteners) with the following: Fasteners used in contact with preservative-treated or fire-retardant-treated lumber must comply with IBC Section 2304.9.5, IRC Section R323.3, or UBC Section 2304.3, as applicable.

8.4 Design and Installation: 2003 IBC, 2003 IRC, 2000 IBC, 2000 IRC, and UBC:

8.4.1 Design: The same as Section 4.1 of this report.

8.4.2 Installation: The same as Section 4.2 of this report.

8.5 Conditions of Use: 2003 IBC, 2003 IRC, 2000 IBC, 2000 IRC, and UBC:

The Simpson Strong-Tie Straight and Coiled Tie Straps described in this report comply with, or are suitable

alternatives to what is specified in, those codes listed in Section 8.1 of this report, subject to the conditions of use described in Sections 5.1 through 5.4 of this report.

8.6 Evidence Submitted: 2003 IBC, 2003 IRC, 2000 IBC, 2000 IRC, and UBC: Same as Section 6.0 of this report.

8.7 Identification: 2003 IBC, 2003 IRC, 2000 IBC, 2000 IRC, and UBC:

Same as Section 7.0 of this report.

TABLE 1A—ALLOWABLE TENSION LOADS FOR THE ST AND FHA SERIES TIE STRAPS BASED ON THE 2006 AND 2003 IBC

MODEL SERIES	MODEL NO.	TIE STRAP PROPERTIES				COMMON NAILS ¹ (Total Quantity–Size)	ALLOWABLE TENSION LOADS ^{2,3,4} (lbs.)	
		Thickness (Gage No.)	Length (inches)	Minimum F_y (ksi)	Minimum F_u (ksi)		$C_D = 1.33$	$C_D = 1.6$
FHA	FHA6	12	6 ³ / ₈	33	45	8–16d	815	945
	FHA9	12	9	33	45	8–16d	815	945
	FHA12	12	11 ⁵ / ₈	33	45	8–16d	815	945
	FHA18	12	17 ³ / ₄	33	45	8–16d	815	945
	FHA24	12	23 ⁷ / ₈	33	45	8–16d	815	945
	FHA30	12	30	33	45	8–16d	815	945
ST	ST292	20	9 ⁵ / ₁₆	33	45	12–16d	1,090	1,265 ⁽⁵⁾
	ST2122	20	12 ¹³ / ₁₆	40	55	16–16d	1,470	1,530 ⁽⁵⁾
	ST2115	20	16 ⁵ / ₁₆	50	65	10–16d	660 ⁽⁵⁾	660 ⁽⁵⁾
	ST2215	20	16 ⁵ / ₁₆	50	65	20–16d	1,850	1,875 ⁽⁵⁾
	ST6215	16	16 ⁵ / ₁₆	33	45	20–16d	1,860	2,095 ⁽⁵⁾
	ST6224	16	23 ⁵ / ₁₆	40	55	28–16d	2,540 ⁽⁵⁾	2,540 ⁽⁵⁾
	ST6236	14	33 ¹³ / ₁₆	50	65	40–16d	3,845 ⁽⁵⁾	3,845 ⁽⁵⁾
	ST9	16	9	33	45	8–16d	745	885
	ST12	16	11 ⁵ / ₈	33	45	10–16d	930	1,105
	ST18	16	17 ³ / ₄	33	45	14–16d	1,300	1,420 ⁽⁵⁾
	ST22	16	21 ⁵ / ₈	33	45	18–16d	1,420 ⁽⁵⁾	1,420 ⁽⁵⁾

For SI: 1 inch = 25.4 mm, 1 lbf = 4.45 N.

¹Quantity of fasteners is the minimum number of common nails required to achieve the tabulated allowable loads. One half of the tabulated quantity must be installed in each wood member forming the connection. Fasteners must comply with Section 3.3.3 of this report.

²Allowable tension loads are based on the steel straps connected to wood members having an assigned or equivalent minimum specific gravity of 0.50.

³Allowable tension loads are the lesser of the tie strap steel strength or the connection strength.

⁴Tabulated allowable tension loads are governed by connection strength, unless noted otherwise. Connection strength is derived by multiplying the number of nails by the minimum value from the yield mode equations in Tables 11.3.1 A and B from the NDS-05 or NDS-01, as applicable, where the side member (i.e., the steel tie strap) dowel bearing strength, F_{ds} , is equal to $2.2F_u/C_D$, where C_D equals 1.33 or 1.6 as shown in the table, and where F_u equals the minimum specified tensile strength value of the steel shown in the table. The tabulated allowable tension loads governed by connection strength have been multiplied by the load duration factor, C_D , noted in the table, and are not permitted to be adjusted for other load durations.

⁵The tabulated allowable tension load is governed by steel strength, and does not include a one-third stress increase or the load duration factor, C_D . The steel strength is the lesser of yielding at the gross section of the strap, the fracture in the net section away from the connection, or fracture at the connection in accordance with Section C2 of AISI-NAS-01 (North American Specification for the Design of Cold-formed Steel Structural Members, including the 2004 Supplement) and NASPEC-2001.

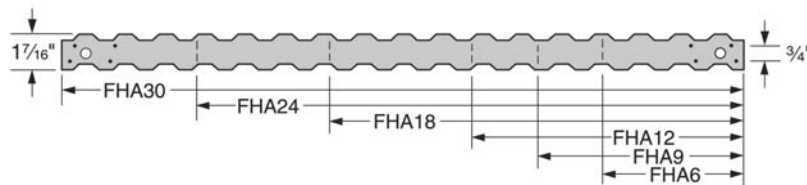

FIGURE 1—FHA SERIES TIE STRAP

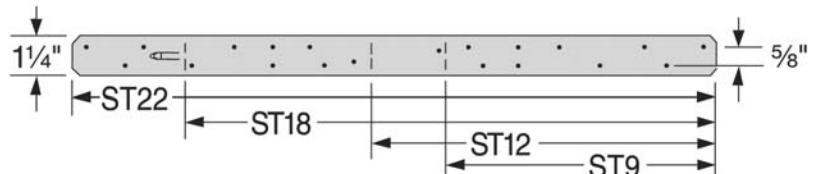

FIGURE 2—ST SERIES TIE STRAPS

TABLE 1B—ALLOWABLE TENSION LOADS FOR THE ST AND FHA SERIES TIE STRAPS BASED ON THE 2000 IBC AND 1997 UBC

MODEL SERIES	MODEL NO.	TIE STRAP PROPERTIES				COMMON NAILS ¹ (Quantity–Size)	ALLOWABLE TENSION LOADS ^{2,3,4} $C_D = 1.33$ (lbs.)
		Thickness (Gage No.)	Length (inches)	Minimum F_y (ksi)	Minimum F_u (ksi)		
FHA	FHA6	12	6 ^{3/8}	33	45	8–16d	750
	FHA9	12	9	33	45	8–16d	750
	FHA12	12	11 ^{5/8}	33	45	8–16d	750
	FHA18	12	17 ^{3/4}	33	45	8–16d	750
	FHA24	12	23 ^{7/8}	33	45	8–16d	750
	FHA30	12	30	33	45	8–16d	750
ST	ST292	20	9 ^{5/16}	33	45	12–16d	1,070
	ST2122	20	12 ^{13/16}	40	55	16–16d	1,440
	ST2115	20	16 ^{5/16}	50	65	10–16d	885 ⁽⁵⁾
	ST2215	20	16 ^{5/16}	50	65	20–16d	1,815
	ST6215	16	16 ^{5/16}	33	45	20–16d	1,800
	ST6224	16	23 ^{5/16}	40	55	28–16d	2,560
	ST6236	14	33 ^{13/16}	50	65	40–16d	3,760
	ST9	16	9	33	45	8–16d	720
	ST12	16	11 ^{5/8}	33	45	10–16d	900
	ST18	16	17 ^{3/4}	33	45	14–16d	1,260
	ST22	16	21 ^{5/8}	33	45	20–16d	1,800

For **SI**: 1 inch = 25.4 mm, 1 lbf = 4.45 N.

¹Quantity of fasteners is the minimum number of common nails required to achieve the tabulated allowable loads. One half of the tabulated quantity must be installed in each wood member forming the connection. Fasteners must comply with Section 3.3.3 of this report.

²Allowable tension loads based on connection strength are for straps nailed to wood members having an assigned or equivalent minimum specific gravity of 0.50.

³Allowable tension loads are the lesser of the tie strap steel strength or the connection strength.

⁴Tabulated allowable tension loads are governed by connection strength, unless noted otherwise. Connection strength is derived by multiplying the number of nails by the minimum value from the yield mode equations in Section 12.3.2 of the NDS-97 (IBC) and NDS-91 (UBC), where the side member (i.e., the steel tie strap) dowel bearing strength, F_{est} , is equal to the minimum specified tensile strength of the steel strap as shown in the table. The tabulated allowable tension loads governed by connection strength have been multiplied by the load duration factor, C_D , noted in the table.

⁵The tabulated allowable tension load is governed by steel strength. The steel strength is the lesser of yielding at the gross section of the strap, the fracture in the net section away from the connection, or fracture at the connection in accordance with Section C2 of the AISI Specifications for the Design of Cold-formed Steel Structural Members (1996 and 1986 editions); and includes a one-third increase as permitted by UBC Section 1612.3.2 (Alternate Basic Load Combinations).

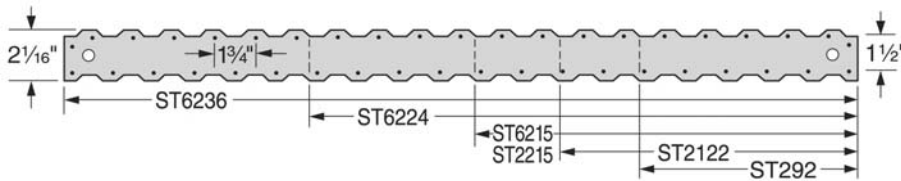

FIGURE 3—ST SERIES TIE STRAPS

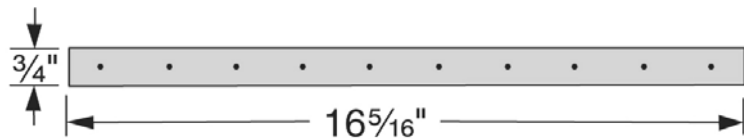

FIGURE 4—ST2115 TIE STRAP

TABLE 2A—ALLOWABLE TENSION LOADS FOR THE HST AND MST SERIES TIE STRAPS BASED ON THE 2006 IBC AND 2003 IBC

MODEL SERIES	MODEL NO.	TIE STRAP PROPERTIES				FASTENERS ¹ (Quantity–Size)		ALLOWABLE TENSION LOADS ^{2,3,4,5} (lbs.)							
								$C_D = 1.33$			$C_D = 1.6$				
		Thick. (Gage No.)	Length (in.)	Min. F_y (ksi)	Min. F_u (ksi)	Nails	Bolts	Nails	Bolts			Nails	Bolts		
									Wood Member Thickness (in.)				Wood Member Thickness (in.)		
3	3 $\frac{1}{2}$								5 $\frac{1}{2}$	3	3 $\frac{1}{2}$		5 $\frac{1}{2}$		
HST	HST2	7	21 $\frac{1}{4}$	40	55	—	6– $\frac{5}{8}$ "	—	4,400	4,385	4,350	—	5,280	5,260	5,220
	HST5	7	21 $\frac{1}{4}$	40	55	—	12– $\frac{5}{8}$ "	—	8,800	8,840	8,875	—	10,560	10,605	10,650
	HST3	3	25 $\frac{1}{2}$	33	52	—	6– $\frac{3}{4}$ "	—	5,730	6,450	6,400	—	6,875	7,740	7,680
	HST6	3	25 $\frac{1}{2}$	33	52	—	12– $\frac{3}{4}$ "	—	11,285	12,700	12,895	—	13,545	15,240	15,475
MST	MST27	12	27	40	55	30–16d	4– $\frac{1}{2}$ "	3,195	1,815	1,810	1,805	3,705	2,175	2,170	2,165
	MST37	12	37 $\frac{1}{2}$	40	55	42–16d	6– $\frac{1}{2}$ "	3,195	2,560	2,550	2,525	3,705	3,075	3,060	3,030
	MST48	12	48	42	56	50–16d	8– $\frac{1}{2}$ "	4,765 ⁽⁶⁾	3,145	3,120	3,065	4,930 ⁽⁶⁾	3,695 ⁽⁶⁾	3,695 ⁽⁶⁾	3,675
	MST60	10	60	42	56	64–16d	10– $\frac{1}{2}$ "	6,490 ⁽⁶⁾	3,885	3,840	3,740	6,730 ⁽⁶⁾	4,665	4,605	4,490
	MST72	10	72	42	56	64–16d	10– $\frac{1}{2}$ "	6,490 ⁽⁶⁾	3,885	3,840	3,740	6,730 ⁽⁶⁾	4,665	4,605	4,490

For SI: 1 inch = 25.4 mm, 1 lbf = 4.45 N.

¹Quantity of fasteners is the total number of common nails or bolts, but not both, required to achieve the tabulated allowable loads. One half of the tabulated quantity must be installed in each wood member forming the connection. Fasteners must comply with Section 3.3.3 of this report.

²Allowable tension loads for nailed and bolted connections are not cumulative.

³Allowable tension loads are based on the steel straps connected to wood members having an assigned or equivalent minimum specific gravity of 0.50.

⁴Allowable tension loads are the lesser of the tie strap steel strength or the connection strength.

⁵Tabulated allowable tension loads are governed by connection strength, unless noted otherwise. Connection strength is derived by multiplying the number of fasteners by the minimum value from the yield mode equations in Tables 11.3.1 A and B from the NDS-05 or NDS-01, as applicable, where the dowel bearing strength, F_{db} , of the side member (i.e., the steel tie strap) is equal to $2.2F_u/C_D$ for nailed and bolted connections, where the load duration factor, C_D , equals 1.33 or 1.6 as shown in the table, and where the minimum specified tensile strength, F_u of the steel strap is as shown in the table. For bolted connections, the tabulated allowable tension loads include the load duration factor, C_D , noted in the table, and the applicable group action factor, C_g .

⁶The tabulated allowable tension load is governed by steel strength, and does not include a one-third stress increase or the load duration factor, C_D . The steel strength is the lesser of yielding at the gross section of the strap, the fracture in the net section away from the connection, or fracture at the connection in accordance with Section C2 of AISI-NAS-01 (North American Specification for the Design of Cold-formed Steel Structural Members, including the 2004 Supplement) and NASPEC-2001.

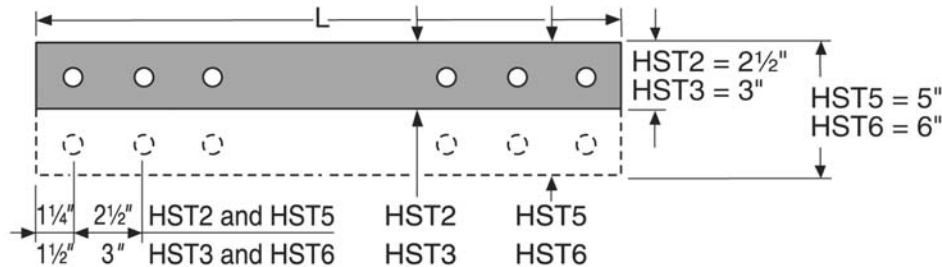

FIGURE 5—HST SERIES TIE STRAP

**TABLE 2B—ALLOWABLE TENSION LOADS FOR THE HST AND MST SERIES TIE STRAPS
BASED ON THE 2000 IBC AND 1997 UBC**

MODEL SERIES	MODEL NO.	TIE STRAP PROPERTIES				FASTENERS ¹ (Quantity–Size)		ALLOWABLE TENSION LOADS ^{2,3,4,5,6} $C_D = 1.33$ (lbs.)			
		Thickness (Gage No.)	Length (in.)	Min. F_y (ksi)	Min. F_u (ksi)	Common Nails	Bolts	Nails	Bolts		
									Wood Member Thickness (in.)		
									3	3 $\frac{1}{2}$	5 $\frac{1}{2}$
HST	HST2	7	21 $\frac{1}{4}$	40	55	—	6– $\frac{5}{8}$ " dia.	—	4,400	4,385	4,350
	HST5	7	21 $\frac{1}{4}$	40	55	—	12– $\frac{5}{8}$ " dia.	—	8,800	8,840	8,875
	HST3	3	25 $\frac{1}{2}$	33	52	—	6– $\frac{3}{4}$ " dia.	—	5,730	6,450	6,400
	HST6	3	25 $\frac{1}{2}$	33	52	—	12– $\frac{3}{4}$ " dia.	—	11,285	12,700	12,895
MST	MST27	12	27	40	55	30–16d	4– $\frac{1}{2}$ " dia.	2,900	1,815	1,810	1,805
	MST37	12	37 $\frac{1}{2}$	40	55	42–16d	6– $\frac{1}{2}$ " dia.	4,060	2,560	2,550	2,525
	MST48	12	48	42	56	50–16d	8– $\frac{1}{2}$ " dia.	4,865	3,145	3,120	3,065
	MST60	10	60	42	56	64–16d	10– $\frac{1}{2}$ " dia.	6,655	3,885	3,840	3,740
	MST72	10	72	42	56	64–16d	10– $\frac{1}{2}$ " dia.	6,655	3,885	3,840	3,740

For SI: 1 inch = 25.4 mm, 1 lbf = 4.45 N.

¹Quantity of fasteners is the total number of nails or bolts, but not both, required to achieve the tabulated allowable loads. One half of the tabulated quantity must be installed in each wood member forming the connection. Fasteners must comply with Section 3.3.3 of this report.

²Allowable tension loads for nailed and bolted connections are not cumulative.

³Allowable tension loads are based on the steel straps connected to wood members having an assigned or equivalent minimum specific gravity of 0.50.

⁴Allowable tension loads are the lesser of the tie strap steel strength or the connection strength.

⁵Tabulated allowable tension loads are governed by connection strength, which is derived by multiplying the number of nails by the minimum value from the yield mode equations in Section 12.3.2 of the NDS-97 (IBC) and NDS-91 (UBC), where the side member (i.e., the steel tie strap) dowel bearing strength, F_{es} , is equal to the minimum specified tensile strength of the steel strap as shown in the table. The tabulated allowable tension loads include the load duration factor, C_D , noted in the table, and an appropriate group action factor, C_g , for bolted connections.

⁶None of the tabulated allowable tension loads are governed by steel strength, provided yielding at the gross section of the strap, fracture in the net section away from the connection, and fracture at the connection in accordance with Section C2 of the AISI Specifications for the Design of Cold-formed Steel Structural Members (1996 and 1986 editions) include a one-third stress increase as permitted by UBC Section 1612.3.2 (Alternate Basic Load Combinations).

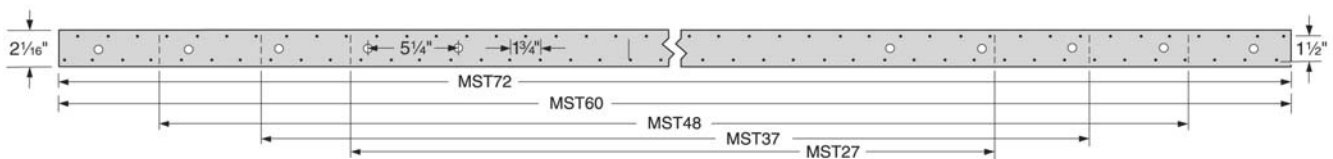

FIGURE 6—MST SERIES TIE STRAP

**TABLE 3A—ALLOWABLE TENSION LOADS FOR THE LSTA, MSTA, LSTI, AND MSTI SERIES TIE STRAPS
BASED ON THE 2006 IBC AND 2003 IBC**

MODEL SERIES	MODEL NO.	TIE STRAP PROPERTIES				NAILS ¹ (Total Quantity–Size)	ALLOWABLE TENSION LOADS ^{2,3,4} (lbs.)	
		Thickness (Gage No.)	Length (inches)	Min. F_y (ksi)	Min. F_u (ksi)		$C_D = 1.33$	$C_D = 1.6$
LSTA	LSTA9	20	9	50	65	8–10d common	620	740
	LSTA12	20	12	50	65	10–10d common	775	925
	LSTA15	20	15	50	65	12–10d common	930	1,110
	LSTA18	20	18	50	65	14–10d common	1,085	1,235 ⁽⁵⁾
	LSTA21	20	21	50	65	16–10d common	1,235 ⁽⁵⁾	1,235 ⁽⁵⁾
	LSTA24	20	24	50	65	18–10d common	1,235 ⁽⁵⁾	1,235 ⁽⁵⁾
	LSTA30	18	30	50	65	22–10d common	1,640 ⁽⁵⁾	1,640 ⁽⁵⁾
MSTA	LSTA36	18	36	50	65	24–10d common	1,640 ⁽⁵⁾	1,640 ⁽⁵⁾
	MSTA9	18	9	50	65	8–10d common	635	750
	MSTA12	18	12	50	65	10–10d common	795	940
	MSTA15	18	15	50	65	12–10d common	955	1,130
	MSTA18	18	18	50	65	14–10d common	1,115	1,315
	MSTA21	18	21	50	65	16–10d common	1,270	1,505
	MSTA24	18	24	50	65	18–10d common	1,430	1,640 ⁽⁵⁾
LSTI	MSTA30	16	30	50	65	22–10d common	1,805	2,050 ⁽⁵⁾
	MSTA36	16	36	50	65	26–10d common	2,050 ⁽⁵⁾	2,050 ⁽⁵⁾
LSTI	LSTI49	18	49	40	55	32–10dx1½ common	2,510	2,975
	LSTI73	18	73	40	55	48–10dx1½ common	3,770	4,205 ⁽⁵⁾
MSTI	MSTI26	12	26	40	55	26–10dx1½ common	2,380	2,745
	MST36	12	36	40	55	36–10dx1½ common	3,295	3,800
	MSTI48	12	48	40	55	48–10dx1½ common	4,390	5,065
	MSTI60	12	60	40	55	60–10dx1½ common	5,080 ⁽⁵⁾	5,080 ⁽⁵⁾
	MSTI72	12	72	40	55	72–10dx1½ common	5,080 ⁽⁵⁾	5,080 ⁽⁵⁾
MSTC	MSTC28	16	28¼	50	65	36–16d sinker	2,950	3,455
	MSTC40	16	40¼	50	65	52–16d sinker	4,265	4,745 ⁽⁵⁾
	MSTC52	16	52¼	50	65	62–16d sinker	4,745 ⁽⁵⁾	4,745 ⁽⁵⁾
	MSTC66	14	65¾	50	65	76–16d sinker	5,860 ⁽⁵⁾	5,860 ⁽⁵⁾
	MSTC78	14	77¾	50	65	76–16d sinker	5,860 ⁽⁵⁾	5,860 ⁽⁵⁾

For **SI**: 1 inch = 25.4 mm, 1 lbf = 4.45 N.

¹Total fasteners are the minimum number of nails required to achieve the tabulated allowable loads. One half of the total must be installed in each wood member forming the connection. Fasteners must comply with Section 3.3.3 of this report.

²Allowable tension loads are based on the steel straps connected to wood members having an assigned or equivalent minimum specific gravity of 0.50.

³Allowable tension loads are the lesser of the tie strap steel strength or the connection strength.

⁴Tabulated allowable tension loads are governed by connection strength, unless noted otherwise. Connection strength is derived by multiplying the number of nails by the minimum value from the yield mode equations in Tables 11.3.1 A and B from the NDS-05 or NDS-01, as applicable, where the side member (i.e., the steel tie strap) dowel bearing strength, F_{db} , is equal to $2.2F_u/C_D$, where the load duration factor, C_D , equals 1.33 or 1.6 as shown in the table, and where the minimum specified tensile strength, F_u of the steel strap is as shown in the table. The tabulated allowable tension loads governed by connection strength have been multiplied by the load duration factor, C_D , noted in the table.

⁵The tabulated allowable tension load is governed by steel strength, and does not include a one-third stress increase or the load duration factor, C_D . The steel strength is the lesser of yielding at the gross section of the strap, the fracture in the net section away from the connection, or fracture at the connection in accordance with Section C2 of AISI-NAS-01 (North American Specification for the Design of Cold-formed Steel Structural Members, including the 2004 Supplement) and NASPEC-2001.

**TABLE 3B—ALLOWABLE TENSION LOADS FOR THE LSTA, MSTA, LSTI, AND MSTI SERIES TIE STRAPS
BASED ON THE 2000 IBC AND 1997 UBC**

MODEL SERIES	MODEL NO.	TIE STRAP PROPERTIES				COMMON NAILS ¹ (Total Quantity–Size)	ALLOWABLE TENSION LOADS ^{2,3,4,5} $C_D = 1.33$ (lbs.)
		Thickness (Gage No.)	Length (inches)	Min. F_y (ksi)	Min. F_u (ksi)		
LSTA	LSTA9	20	9	50	65	8–10d common	610
	LSTA12	20	12	50	65	10–10d common	760
	LSTA15	20	15	50	65	12–10d common	910
	LSTA18	20	18	50	65	14–10d common	1,065
	LSTA21	20	21	50	65	16–10d common	1,215
	LSTA24	20	24	50	65	18–10d common	1,370
	LSTA30	18	30	50	65	22–10d common	1,685
LSTA36	18	36	50	65	26–10d common	1,995	
MSTA	MSTA9	18	9	50	65	8–10d common	615
	MSTA12	18	12	50	65	10–10d common	765
	MSTA15	18	15	50	65	12–10d common	920
	MSTA18	18	18	50	65	14–10d common	1,075
	MSTA21	18	21	50	65	16–10d common	1,225
	MSTA24	18	24	50	65	18–10d common	1,380
	MSTA30	16	30	50	65	22–10d common	1,700
MSTA36	16	36	50	65	26–10d common	2,010	
LSTI	LSTI49	18	49	40	55	32–10dx1½ common	1,985
	LSTI73	18	73	40	55	48–10dx1½ common	2,975
MSTI	MSTI26	12	26	40	55	26–10dx1½ common	1,680
	MSTI36	12	36	40	55	36–10dx1½ common	2,330
	MSTI48	12	48	40	55	48–10dx1½ common	3,105
	MSTI60	12	60	40	55	60–10dx1½ common	3,880
	MSTI72	12	72	40	55	72–10dx1½ common	4,655
MSTC	MSTC28	16	28¼	50	65	36–16d sinker	2,775
	MSTC40	16	40¼	50	65	52–16d sinker	4,010
	MSTC52	16	52¼	50	65	62–16d sinker	4,785
	MSTC66	14	65¾	50	65	76–16d sinker	6,015
	MSTC78	14	77¾	50	65	76–16d sinker	6,015

For **SI**: 1 inch = 25.4 mm, 1 lbf = 4.45 N.

¹Total fasteners are the minimum number of nails to achieve the tabulated allowable loads. One half of the total must be installed in each wood member forming the connection. Fasteners must comply with Section 3.3.3 of this report.

²Allowable tension loads are based on the steel straps connected to wood members having an assigned or equivalent minimum specific gravity of 0.50.

³Allowable tension loads are the lesser of the tie strap steel strength or the connection strength.

⁴Tabulated allowable tension loads are governed by connection strength, which is derived by multiplying the number of nails by the minimum value from the yield mode equations in Section 12.3.2 of the NDS-97 (IBC) and NDS-91 (UBC), where the side member (i.e., the steel tie strap) dowel bearing strength, F_{db} , is equal to the minimum specified tensile strength, F_u , of the steel strap as shown in the table. The tabulated allowable tension loads include the load duration factor, C_D , noted in the table.

⁵None of the tabulated allowable tension loads are governed by steel strength, provided yielding at the gross section of the strap, fracture in the net section away from the connection, and fracture at the connection in accordance with Section C2 of the AISI Specifications for the Design of Cold-formed Steel Structural Members (1996 and 1986 editions) include a one-third stress increase as permitted by UBC Section 1612.3.2 (Alternate Basic Load Combinations).

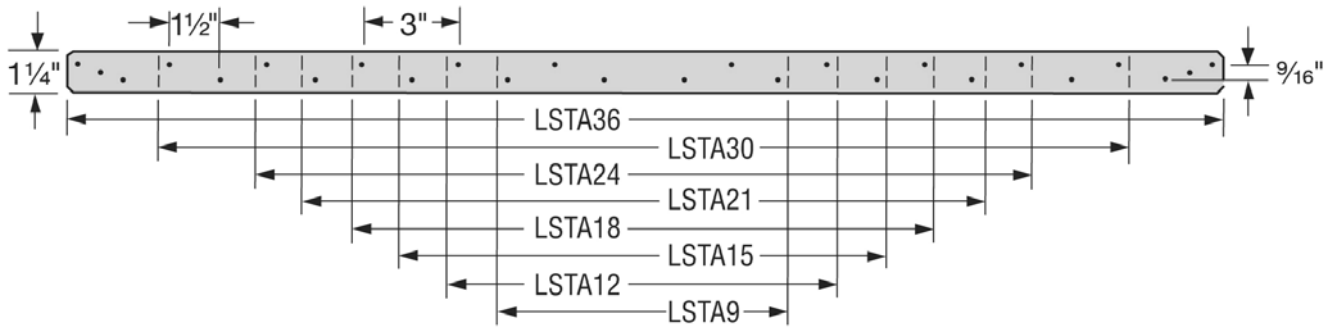

FIGURE 7—LSTA SERIES (MSTA SERIES SIMILAR) TIE STRAP

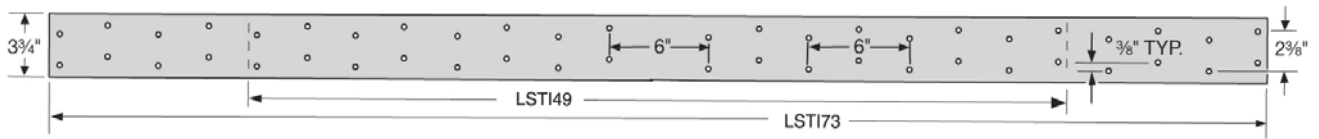

FIGURE 8—LSTI SERIES TIE STRAP

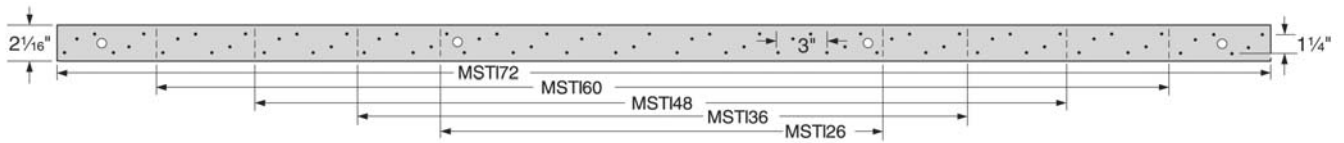

FIGURE 9—MSTI SERIES TIE STRAP

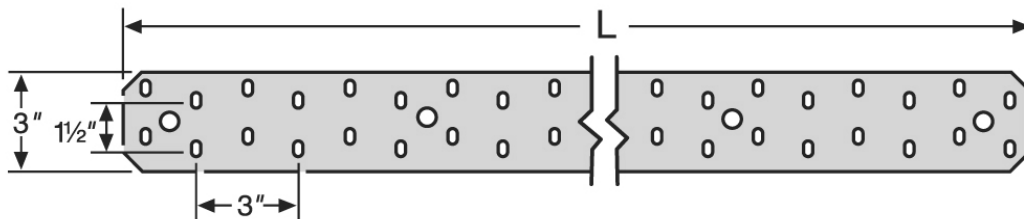

FIGURE 10—MSTC SERIES TIE STRAP

TABLE 4A—ALLOWABLE TENSION LOADS FOR THE CS AND CMST SERIES
AND THE CMSTC16 COIL TIE STRAPS BASED ON THE 2006 IBC AND 2003 IBC

MODEL SERIES	MODEL NO.	TIE STRAP PROPERTIES				NAILS ¹ (Quantity—Size)	ALLOWABLE TENSION LOADS ^{2,3} (lbs.)		
		Thickness (Gage No.)	Length	Min. F_y (ksi)	Min. F_u (ksi)		Based on Connection Strength ⁴		Based on Steel Strength ⁵
							$C_D = 1.33$	$C_D = 1.6$	
CS	CS14	14	Cut to length	50	65	30–10d common	2,565	2,985	2,490
						36–8d common	2,575	3,005	2,490
	CS16	16	Cut to length	40	55	22–10d common	1,760	2,080	1,705
						28–8d common	1,875	2,200	1,705
	CS18	18	Cut to length	40	55	18–10d common	1,415	1,675	1,370
						22–8d common	1,430	1,695	1,370
	CS20	20	Cut to length	40	55	14–10d common	1,080	1,280	1,030
						18–8d common	1,150	1,370	1,030
	CS22	22	Cut to length	40	55	12–10d common	920	1,100	845
						14–8d common	890	1,055	845
CMST	CMST12	12	Cut to length	50	65	84–16d common	9,280	10,710	9,215
						96–10d common	9,170	10,560	9,215
	CMST14	14	Cut to length	50	65	66–16d common	6,600	7,755	6,490
						78–10d common	6,670	7,760	6,490
CMSTC	CMSTC16	16	Cut to length	50	65	56–16d sinker	4,590	5,375	4,585

For SI: 1 inch = 25.4 mm, 1 lbf = 4.45 N.

¹Total fasteners are the minimum number of nails required to achieve the tabulated allowable loads. One half of the total must be installed in each wood member forming the connection. Fasteners must comply with Section 3.3.3 of this report.

²Allowable tension loads are based on the steel straps connected to wood members having an assigned or equivalent minimum specific gravity of 0.50.

³Allowable tension loads must be the lesser of the tie strap steel strength or the connection strength.

⁴Allowable tension loads based on connection strength are derived by multiplying the number of nails by the minimum value from the yield mode equations in Tables 11.3.1 A and B NDS-01 or NDS-05, as applicable, where the side member (i.e., the steel tie strap) dowel bearing strength, F_{ds} , is equal to $2.2F_u/C_D$, where C_D equals 1.33 or 1.6 as shown in the table, and where the minimum specified tensile strength, F_u , of the steel strap is as shown in the table. Allowable tension loads governed by connection strength have been multiplied by the load duration factor, C_D , noted in the table.

⁵The tabulated allowable tension loads based on steel strength do not include a one-third stress increase, and are the lesser of yielding at the gross section of the strap, the fracture in the net section away from the connection, or fracture at the connection in accordance with Section C2 of AISI-NAS-01 (North American Specification for the Design of Cold-formed Steel Structural Members, including the 2004 Supplement) and NASPEC-2001.

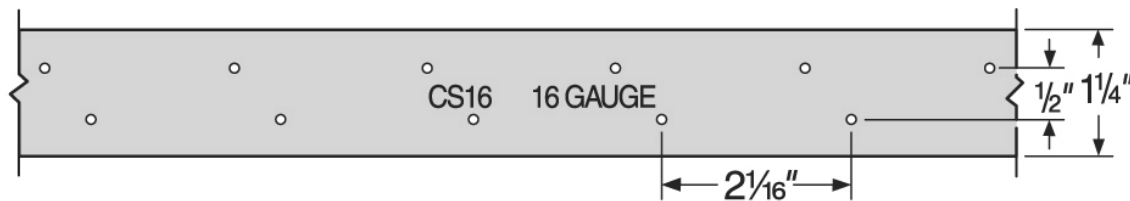

FIGURE 11—CS SERIES TIE STRAP

TABLE 4B—ALLOWABLE TENSION LOADS FOR THE CS AND CMST SERIES AND THE CMSTC16 COIL TIE STRAPS BASED ON THE 2000 IBC AND 1997 UBC

MODEL SERIES	MODEL NO.	TIE STRAP PROPERTIES				NAILS ¹ (Total Quantity—Size)	ALLOWABLE TENSION LOADS ^{2,3} (lbs.)	
		Thickness (Gage No.)	Length	Min. F_y (ksi)	Min. F_u (ksi)		Based on Connection Strength ⁴ , $C_D = 1.33$	Based on Steel Strength ⁵
CS	CS14	14	Cut to length	50	65	42–10d common	3,325	3,320
						52–8d common	3,425	3,320
	CS16	16	Cut to length	40	55	30–10d common	2,295	2,275
						36–8d common	2,275	2,275
	CS18	18	Cut to length	40	55	24–10d common	1,820	1,825
						30–8d common	1,875	1,825
	CS20	20	Cut to length	40	55	20–10d common	1,505	1,370
						24–8d common	1,490	1,370
CS22	22	Cut to length	40	55	16–10d common	1,200	1,125	
					20–8d common	1,240	1,125	
CMST	CMST12	12	Cut to length	50	65	124–16d common	12,370	12,285
						144–10d common	12,255	12,285
	CMST14	14	Cut to length	50	65	92–16d common	8,650	8,635
CMSTC	CMSTC16	16	Cut to length	50	65	80–16d sinker	6,170	6,115

For SI: 1 inch = 25.4 mm, 1 lbf = 4.45 N.

¹Total quantity of fasteners is the minimum number of nails required to achieve the tabulated allowable loads. One half of the total must be installed in each wood member forming the connection. Fasteners must comply with Section 3.3.3 of this report.

²Allowable tension loads are based on the steel straps connected to wood members having an assigned or equivalent minimum specific gravity of 0.50.

³Allowable tension loads are the lesser of the tie strap steel strength or the connection strength.

⁴Allowable tension loads based on connection strength are derived by multiplying the number of nails by the minimum value from the yield mode equations in Section 12.3.2 of the NDS-97 (IBC) and NDS-91 (UBC), where the side member (i.e., the steel tie strap) dowel bearing strength, F_{ds} , is equal to the minimum specified tensile strength of the steel strap as shown in the table. The allowable tension loads include the load duration factor, C_D , noted in the table.

⁵The tabulated allowable tension loads governed by steel strength are the lesser of yielding at the gross section of the strap, the fracture in the net section away from the connection, or fracture at the connection in accordance with Section C2 of the AISI Specifications for the Design of Cold-formed Steel Structural Members (1996 and 1986 editions); and include a one-third increase as permitted by UBC Section 1612.3.2 (Alternate Basic Load Combinations).

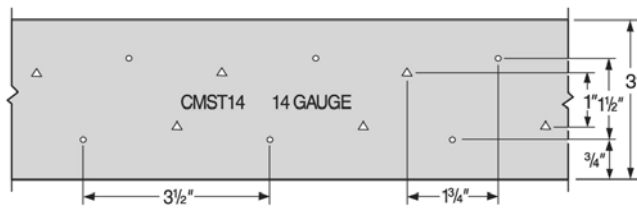

FIGURE 12—CMST14 TIE STRAP

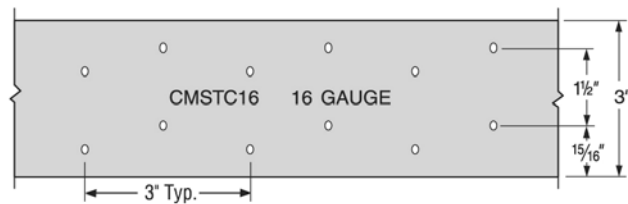

FIGURE 13—CMSTC16 TIE STRAP

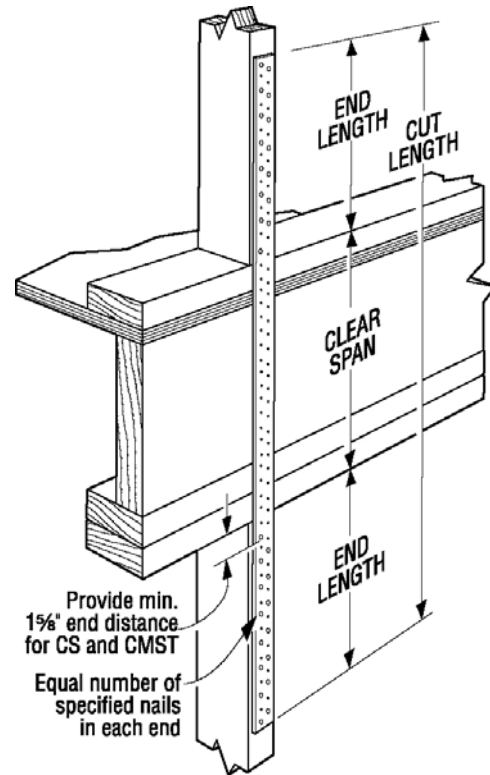

FIGURE 14—TYPICAL INSTALLATION OF CS, CMST, AND CMSTC16 TIE STRAP