

# ESR-2553

Used for Florida State Wide Product Approval #

## FL10856

Products on this Report which are approved:

| <u>Product</u> | <u>FL#</u> | <u>Product</u> | <u>FL#</u> | <u>Product</u> | <u>FL#</u> | <u>Product</u> | <u>FL#</u> |
|----------------|------------|----------------|------------|----------------|------------|----------------|------------|
| HU210-2TF      | 10856.1    | HU612TF        | 10856.9    | HW88           | 10856.11   | W36            | 10856.17   |
| HU210-3TF      | 10856.1    | HU614TF        | 10856.9    | HWU410         | 10856.12   | W38            | 10856.17   |
| HU210TF        | 10856.2    | HU616TF        | 10856.9    | HWU412         | 10856.12   | W410           | 10856.17   |
| HU212-2TF      | 10856.3    | HU66TF         | 10856.9    | HWU414         | 10856.12   | W44            | 10856.17   |
| HU212-3TF      | 10856.3    | HU68TF         | 10856.9    | HWU416         | 10856.12   | W46            | 10856.17   |
| HU212TF        | 10856.3    | HUS210-2TF     | 10856.10   | JB210          | 10856.13   | W48            | 10856.17   |
| HU214-2TF      | 10856.3    | HUS212-2TF     | 10856.10   | JB212          | 10856.13   | WNP210-2       | 10856.18   |
| HU214-3TF      | 10856.3    | HUS214-2TF     | 10856.10   | JB214          | 10856.13   | WNP212-2       | 10856.18   |
| HU214TF        | 10856.3    | HUS26-2TF      | 10856.10   | JB26           | 10856.13   | WNP214-2       | 10856.18   |
| HU216-2        | 10856.3    | HUS28-2TF      | 10856.10   | JB28           | 10856.13   | WNP216-2       | 10856.18   |
| HU216-2TF      | 10856.3    | HUS410TF       | 10856.10   | LB210          | 10856.14   | WNP26-2        | 10856.18   |
| HU216-3TF      | 10856.3    | HUS412TF       | 10856.10   | LB212          | 10856.14   | WNP28-2        | 10856.18   |
| HU216TF        | 10856.3    | HUS414TF       | 10856.10   | LB214          | 10856.14   | WNP312         | 10856.18   |
| HU24-2TF       | 10856.4    | HUS46TF        | 10856.10   | LB216          | 10856.14   | WNP314         | 10856.18   |
| HU24TF         | 10856.4    | HUS48TF        | 10856.10   | LB26           | 10856.14   | WNP316         | 10856.18   |
| HU26-2TF       | 10856.4    | HW3.25         | 10856.11   | LB28           | 10856.14   | WNP412         | 10856.18   |
| HU26TF         | 10856.4    | HW410          | 10856.11   | PF24           | 10856.15   | WNP414         | 10856.18   |
| HU28-2TF       | 10856.4    | HW412          | 10856.11   | PF24A          | 10856.15   | WNP416         | 10856.18   |
| HU28TF         | 10856.4    | HW414          | 10856.11   | PF24Z          | 10856.15   | WNP610         | 10856.18   |
| HU310TF        | 10856.5    | HW416          | 10856.11   | PF26           | 10856.15   | WNP66          | 10856.18   |
| HU312TF        | 10856.5    | HW46           | 10856.11   | PF26A          | 10856.15   | WNP68          | 10856.18   |
| HU314TF        | 10856.5    | HW48           | 10856.11   | PF26Z          | 10856.15   | WNPU210-2      | 10856.19   |
| HU316TF        | 10856.5    | HW5.25         | 10856.11   | PFD24          | 10856.15   | WNPU212-2      | 10856.19   |
| HU34TF         | 10856.6    | HW610          | 10856.11   | PFD26          | 10856.15   | WNPU214-2      | 10856.19   |
| HU36TF         | 10856.6    | HW612          | 10856.11   | PFDS26         | 10856.15   | WNPU216-2      | 10856.19   |
| HU38TF         | 10856.6    | HW614          | 10856.11   | RR             | 10856.16   | WNPU312        | 10856.19   |
| HU410TF        | 10856.7    | HW616          | 10856.11   | W210           | 10856.17   | WNPU314        | 10856.19   |
| HU412TF        | 10856.7    | HW66           | 10856.11   | W212           | 10856.17   | WNPU316        | 10856.19   |
| HU414TF        | 10856.7    | HW68           | 10856.11   | W214           | 10856.17   | WNPU412        | 10856.19   |
| HU416TF        | 10856.7    | HW810          | 10856.11   | W216           | 10856.17   | WNPU414        | 10856.19   |
| HU44TF         | 10856.8    | HW812          | 10856.11   | W26            | 10856.17   | WNPU416        | 10856.19   |
| HU46TF         | 10856.8    | HW814          | 10856.11   | W28            | 10856.17   |                |            |
| HU48TF         | 10856.8    | HW816          | 10856.11   | W310           | 10856.17   |                |            |
| HU610TF        | 10856.9    | HW86           | 10856.11   | W34            | 10856.17   |                |            |

**SIMPSON**

**Strong-Tie**

®

**SIMPSON STRONG-TIE COMPANY, INC.**

**ICC Evaluation Service, Inc.**  
[www.icc-es.org](http://www.icc-es.org)

**Business/Regional Office** ■ 5360 Workman Mill Road, Whittier, California 90601 ■ (562) 699-0543  
**Regional Office** ■ 900 Montclair Road, Suite A, Birmingham, Alabama 35213 ■ (205) 599-9800  
**Regional Office** ■ 4051 West Flossmoor Road, Country Club Hills, Illinois 60478 ■ (708) 799-2305

**DIVISION: 06—WOOD AND PLASTICS**  
**Section: 06090—Wood and Plastic Fastenings**

**REPORT HOLDER:**

**SIMPSON STRONG-TIE COMPANY, INC.**  
5956 WEST LAS POSITAS BOULEVARD  
PLEASANTON, CALIFORNIA 94588  
(800) 925-5099  
[www.strongtie.com](http://www.strongtie.com)

**EVALUATION SUBJECT:**

**SIMPSON STRONG-TIE TOP-FLANGE HANGERS FOR  
SAWN LUMBER**

**1.0 EVALUATION SCOPE**

**Compliance with the following codes:**

- 2006 *International Building Code*® (IBC)
- 2006 *International Residential Code*® (IRC)
- Other Codes (see Section 8.0)

**Property evaluated:**

Structural

**2.0 USES**

The Simpson Strong-Tie top-flange hangers described in this report are used as wood framing connectors in accordance with Section 2304.9.3 of the IBC. The products may also be used in structures regulated under the IRC when an engineered design is submitted in accordance with Section R301.1.3 of the IRC.

**3.0 DESCRIPTION**

**3.1 General:**

The Simpson Strong-Tie top-flange hangers described in this report are U-shaped hangers with one or two flanges that bear onto the supporting wood member or welded to a steel beam. A hanger with two flanges is fabricated from the same piece of steel that forms the U-shaped stirrup of the hanger. A hanger with one flange is fabricated from a steel angle that is factory-welded to the U-shaped stirrup of the hanger. The U-shaped stirrup of each hanger has a width and height designed to support sawn lumber joists or beams.

**3.1.1 JB and LB Hanger Series:** The JB series hangers are fabricated from No. 18 gage galvanized steel, and the LB hangers are fabricated from No. 14 gage galvanized steel. The top flange must be supported by a wood beam, girder, nailer or ledger. Alternatively, the top flange of the LB hangers may be welded to a steel beam. See Table 1 for hanger dimensions, fastener schedules, and allowable loads.

See Figures 1a and 1b for drawings of a typical LB and JB hangers, respectively.

**3.1.2 W, WNP, WNPU, HW, and HWU Hanger Series:** The W hanger series consists of No. 12 gage steel angles factory-welded to No. 12 gage U-shaped steel stirrups. The WNP and WNPU hanger series consist of No. 7 gage steel angles factory-welded to No. 12 gage steel U-shaped stirrups. The HW hanger series consists of No. 3 gage steel angles factory-welded to No. 11 gage steel U-shaped stirrups. The HWU hanger series consists of No. 3 gage steel angles factory-welded to No. 10 gage steel U-shaped stirrups. See Table 2a for a hanger model numbers and seat width and hanger height dimensions. See Table 2b for fastener schedules and allowable loads based on hanger model dimensions. See Figures 2a through 2e for drawings of the W, WNP, HW, HWU, and WNPU hanger series showing top flange dimensions.

**3.1.3 HUTF Hanger Series:** The HUTF hanger series is formed from No. 12 gage galvanized steel. HUTF hangers have two header flanges, which extend over the top of the header, and have predrilled holes for the installation of 16d common nails as shown in Figure 3b. The hanger seat width (W) is sized for the net width of the supported member. HUTF hangers having a seat width equal to or greater than 2<sup>9</sup>/<sub>16</sub> inches (65 mm) are available with concealed header flanges (i.e., the portion of the hanger fastened to the carrying header) as shown in Figure 3b. See Table 3 for hanger models, hanger dimensions, fastener schedules, and allowable loads.

**3.1.4 HUSTF Series Hangers:** The HUSTF Series joist hangers are fabricated from No. 14 gage galvanized steel. The hanger has a U-shaped stirrup with prepunched holes for installing nails, minimum 16d common, that must be driven at a 45-degree angle through the supported wood joist and into the carrying wood member. This is described in the manufacturer's installation instructions as double shear nailing. See Table 4 for hanger models, hanger dimensions, fastener schedules, and allowable loads. See Figure 4a for a drawing of a typical HUSTF hanger, and Figure 4b for drawing of a top view of double shear nailing.

**3.1.5 PF, PFD, PFA, and PFDS Hanger Series:** The PF hangers support nominally 2-by-4 and 2-by-6 wood members and are fabricated from No. 18 gage galvanized steel. The PFA, PFD and PFDS hangers support nominally 2-by-4 or 2-by-6 wood joists and are fabricated from No. 20 gage galvanized steel. The PFA hangers support a single joist member. The PFD and PFDS hangers, which are installed in a saddle configuration over the carrying wood member, support two horizontally aligned joists. The U-shaped portion of the hangers have prepunched holes for installing nails, minimum 10d common, that must be driven at a 45-degree angle through the supported wood joist and into the carrying wood member. This is described as double shear nailing in

the installation instructions. See Table 5 for hanger dimensions, fastener schedules, and allowable loads. See Figure 5a for a drawing of the PF24 and PF26 hangers; Figure 5b for a drawing of the PFD24, PFD26, and PFDS26 hangers; Figure 5c for a drawing of the PF24A and PF26A hangers; and Figure 5d for a top view of double shear nailing.

**3.1.6 RR Ridge Rafter Connector:** The RR ridge rafter connector supports nominally 2-inch-wide sawn wood roof rafters from a sawn wood ridge board or beam. The hanger is fabricated from No. 18 gage galvanized steel. The top flange of the RR connector is configured to interlock with an RR connector installed on the opposing face of the ridge board as shown in Figure 6. The RR connector may be used with a rafter having a maximum slope of 7:12 (30 degrees). See Table 6 for fastener schedules and allowable loads. See Figure 6 for a drawing of the RR connector and a typical connector installation detail.

## 3.2 Materials:

**3.2.1 Steel:** The galvanized hangers described in this report are manufactured from steel complying with ASTM A 653, SS designation, Grade 33. The ungalvanized hangers described in this report are fabricated from ASTM A 1011, SS designation, Grade 33. The steel used to fabricate the hangers comply with the following:

| MODEL SERIES | ASTM STEEL SPECIFICATION | MINIMUM STRENGTH (ksi) |                | NOMINAL THICKNESS (gage) | MINIMUM BASE-METAL THICKNESS (inch) |        |
|--------------|--------------------------|------------------------|----------------|--------------------------|-------------------------------------|--------|
|              |                          | Yield, $F_y$           | Tensile, $F_u$ |                          |                                     |        |
| JB           | A 653                    | 33                     | 45             | No. 18                   | 0.0445                              |        |
| LB           | A 653                    | 33                     | 45             | No. 14                   | 0.0685                              |        |
| W            | U-shaped Stirrup         | A 1011                 | 33             | 52                       | No. 12                              | 0.0955 |
|              | Flange                   | A 1011                 | 33             | 52                       | No. 12                              | 0.0955 |
| WNP, WNPU    | U-shaped Stirrup         | A 1011                 | 33             | 52                       | No. 12                              | 0.0955 |
|              | Flange                   | A 1011                 | 33             | 52                       | No. 7                               | 0.0955 |
| WNP, WNPU    | Flange                   | A 1011                 | 33             | 52                       | No. 7                               | 0.1705 |
| HW           | U-shaped Stirrup         | A 1011                 | 33             | 52                       | No. 11                              | 0.1105 |
|              | Flange                   | A 1011                 | 33             | 52                       | No. 3                               | 0.2285 |
| HWU          | U-shaped Stirrup         | A 1011                 | 33             | 52                       | No. 10                              | 0.1255 |
|              | Flange                   | A 1011                 | 33             | 52                       | No. 3                               | 0.2285 |
| HUTF         | A 653                    | 33                     | 45             | No. 12                   | 0.0975                              |        |
| HUSTF        | A 653                    | 33                     | 45             | No. 14                   | 0.0685                              |        |
| PF           | A 653                    | 33                     | 45             | No. 18                   | 0.0445                              |        |
| PFD          | A 653                    | 33                     | 45             | No. 20                   | 0.0335                              |        |
| PFDS         | A 653                    | 33                     | 45             | No. 20                   | 0.0335                              |        |
| RR           | A 653                    | 33                     | 45             | No. 18                   | 0.0445                              |        |

For SI: 1 inch = 25.4 mm, 1 psi = 6.895 kPa.

The galvanized hangers have a minimum G90 zinc coating specification in accordance with ASTM A 653. Some models (designated with a model number ending with Z) are available with a G185 zinc coating specification in accordance with ASTM A 653. Some models (designated with a model number ending with HDG) are available with a hot-dip galvanization, also known as "batch" galvanization, in accordance with ASTM A 123, with a minimum specified coating weight of 2.0 ounces of zinc per square foot of surface area (610 g/m<sup>2</sup>), total for both sides. Model numbers in this report do not include the Z or HDG ending, but the information shown applies. The lumber treater and the holder of this report (Simpson Strong-Tie Company) should be contacted for recommendations on the appropriate level of corrosion resistance to specify for use of the steel connectors in contact with the specific proprietary preservative treated or fire retardant treated lumber.

**3.2.2 Wood:** Wood members with which the connectors are used must be either sawn lumber or engineered lumber having a minimum specific gravity of 0.50 (minimum equivalent specific gravity of 0.50 for engineered lumber), and having a maximum moisture content of 19 percent (16 percent for engineered lumber) except as noted in Section 4.1. The thickness of the supporting wood member (header) must be equal to or greater than the length of the fasteners specified in the tables in this report, or as required by wood member design, whichever is greater.

**3.2.3 Nails used for hangers described in this report must comply with the material requirements, physical properties, tolerances, workmanship, protective coating and finishes, certification, and packaging and package marking requirements specified in ASTM F 1667. The nails must have the following minimum fastener dimensions and bending yield strengths ( $F_{yb}$ ):**

| FASTENER              | SHANK DIAMETER (inch) | NAIL LENGTH (inches) | $F_{yb}$ (psi) |
|-----------------------|-----------------------|----------------------|----------------|
| 10d x 1 $\frac{1}{2}$ | 0.148                 | 1 $\frac{1}{2}$      | 90,000         |
| 10d                   | 0.148                 | 3                    | 90,000         |
| 16d                   | 0.162                 | 3 $\frac{1}{2}$      | 90,000         |

For SI: 1 incAh = 25.4 mm, 1 psi = 6.895 kPa.

Fasteners used in contact with preservative treated or fire retardant treated lumber must comply with IBC Section 2304.9.5 or IRC Section R319.3, as applicable. For use with treated lumber, the lumber treater or this report holder (Simpson Strong-Tie Company), or both, should be contacted for recommendations on the appropriate level of corrosion resistance to specify for the fasteners as well as the connection capacities of fasteners used with the specific proprietary preservative treated or fire retardant treated lumber.

## 4.0 DESIGN AND INSTALLATION

### 4.1 Design:

The tabulated allowable loads shown in this report are based on allowable stress design (ASD) and include the load duration factor,  $C_D$ , corresponding with the applicable loads in accordance with the NDS.

Tabulated allowable loads apply to products connected to wood used under dry conditions and where sustained temperatures are 100°F (37.8°C) or less. When products are installed to wood having a moisture content greater than 19 percent (16 percent for engineered wood products), or where wet service is expected, the allowable loads must be adjusted by the wet service factor,  $C_M$ , specified in the NDS. When connectors are installed in wood that will experience sustained exposure to temperatures exceeding 100°F (37.8°C), the allowable loads in this report must be adjusted by the temperature factor,  $C_t$ , specified in the NDS.

Connected wood members must be analyzed for load-carrying capacity at the connection in accordance with the NDS.

### 4.2 Installation:

Installation of the connectors must be in accordance with this evaluation report and the manufacturer's published installation instructions. In the event of a conflict between this report and the manufacturer's published installation instructions, this report governs.

## 5.0 CONDITIONS OF USE

The Simpson Strong-Tie top-flange hangers for solid-sawn lumber described in this report comply with, or are suitable alternatives to what is specified in, those codes listed in Section 1.0 of this report, subject to the following conditions:

- 5.1** The connectors must be manufactured, identified and installed in accordance with this report and the manufacturer's published installation instructions. A copy of the instructions must be available at the jobsite at all times during installation.
- 5.2** Calculations showing compliance with this report must be submitted to the code official. The calculations must be prepared by a registered design professional where required by the statutes of the jurisdiction in which the project is to be constructed.
- 5.3** Adjustment factors noted in Section 4.1 and the applicable codes must be considered, where applicable.
- 5.4** Connected wood members and fasteners must comply, respectively, with Sections 3.2.2 and 3.2.3 of this report.
- 5.5** Use of connectors with preservative treated or fire retardant treated lumber must be in accordance with Section 3.2.1 of this report. Use of fasteners with preservative treated or fire retardant treated lumber must be in accordance with Section 3.2.3 of this report.
- 5.6** Welded hangers are manufactured under a quality program with inspections by Professional Service Industries, Inc. (AA-660) or by Intertek Testing Services NA, Inc. (AA-688).

## 6.0 EVIDENCE SUBMITTED

Data in accordance with the ICC-ES Acceptance Criteria for Joist Hangers and Similar Devices (AC13), dated October 2006 (corrected March 2007).

## 7.0 IDENTIFICATION

The products described in this report are identified with a die-stamped label indicating the name of the manufacturer (Simpson Strong-Tie), the model number, and the number of an index evaluation report (ESR-2523) that is used as an identifier for the products recognized in this report. Additionally, the factory-welded hangers manufactured in the United States are identified with the acronym of the inspection agency (PSI), and factory-welded hangers manufactured in Canada are identified with the name of the inspection agency (Intertek).

## 8.0 OTHER CODES

### 8.1 Evaluation Scope

In addition to the codes referenced in Section 1.0, the products in this report were evaluated for compliance with the requirements of the following codes:

- 2003 *International Building Code*<sup>®</sup> (2003 IBC)
- 2003 *International Residential Code*<sup>®</sup> (2003 IRC)
- 2000 *International Building Code*<sup>®</sup> (2000 IBC)
- 2000 *International Residential Code*<sup>®</sup> (2000 IRC)
- 1997 *Uniform Building Code*<sup>™</sup> (UBC)

The products described in this report comply with, or are suitable alternatives to what is specified in, the codes listed above, subject to the provisions of Sections 8.2 through 8.7.

### 8.2 Uses:

**8.2.1 2003 IBC, 2003 IRC, 2000 IBC, and 2000 IRC:** See Section 2.0 of this report.

**8.2.2 UBC:** Replace the information in Section 2.0 with the following: Simpson Strong-Tie top-flange hangers are used as wood framing connectors in accordance with Section 2318.4.8 of the UBC.

### 8.3 Description:

**8.3.1 2003 IBC and 2003 IRC:** See Section 3.0 of this report.

**8.3.2 2000 IBC and 2000 IRC:** See Section 3.0 of this report, except modify Section 3.2.3 to reference Section R323.3 of the IRC.

**8.3.3 UBC:** See Section 3.0 of this report, except modify the first sentence in the last paragraph of Section 3.2.3 as follows: Fasteners used in contact with preservative treated or fire retardant treated lumber must, as a minimum, comply with UBC Section 2304.3.

### 8.4 Design and Installation: 2003 IBC, 2003 IRC, 2000 IBC, 2000 IRC, and UBC:

See Section 4.0 of his report.

### 8.5 Conditions of Use:

**8.5.1 2003 IBC, 2003 IRC 2000 IBC, and 2000 IRC:** The Simpson Strong-Tie products described in this report comply with, or are suitable alternatives to what is specified in, those codes listed in Section 8.0, subject to the same conditions of use indicated in Section 5.0 of this report.

**8.5.2 UBC:** The Simpson Strong-Tie products described in this report comply with, or are suitable alternatives to what is specified in, the UBC, subject to the same conditions of use indicated in Section 5.0 of this report, except the last sentence of Section 5.5 is replaced with the following: Fasteners used in contact with preservative treated or fire retardant treated lumber must, as a minimum, comply with UBC Section 2304.3.

### 8.6 Evidence Submitted: 2003 IBC, 2003 IRC 2000 IBC, 2000 IRC, and UBC:

See Section 6.0 of this report.

### 8.7 Identification: 2003 IBC, 2003 IRC 2000 IBC, 2000 IRC, and UBC:

See Section 7.0 of this report.

TABLE 1—ALLOWABLE LOADS FOR THE JB AND LB SERIES JOIST HANGERS

| HANGER SERIES | MODEL NO. | HANGER DIMENSIONS <sup>1</sup><br>(inches) |                                |                               |                                | COMMON NAILS<br>(Quantity – Size) |                                     | ALLOWABLE LOADS <sup>2,3,4</sup><br>(lbs)                  |   |
|---------------|-----------|--|--------------------------------|-------------------------------|--------------------------------|-----------------------------------|-------------------------------------|--|---|
|               |           | W  | H                              | B                             | TF                             | Header                            | Joist                               | Uplift <sup>5</sup><br>where $C_D=1.33$<br>or<br>$C_D=1.6$ | Download<br>where $C_D = 1.0$ ,<br>$C_D = 1.15$ ,<br>$C_D = 1.25$ |
| JB            | JB26      | 1 <sup>9</sup> / <sub>16</sub>             | 5 <sup>3</sup> / <sub>8</sub>  | 1 <sup>1</sup> / <sub>2</sub> | 1 <sup>5</sup> / <sub>16</sub> | 4–10d                             | —                                   | —  | 1,040   |
|               | JB28      | 1 <sup>9</sup> / <sub>16</sub>             | 7 <sup>1</sup> / <sub>4</sub>  | 1 <sup>1</sup> / <sub>2</sub> | 1 <sup>5</sup> / <sub>16</sub> | 4–10d                             | —                                   | —  | 1,050   |
|               | JB210     | 1 <sup>9</sup> / <sub>16</sub>             | 9 <sup>1</sup> / <sub>4</sub>  | 2                             | 1 <sup>3</sup> / <sub>16</sub> | 4–16d                             | —                                   | —  | 1,255   |
|               | JB212     | 1 <sup>9</sup> / <sub>16</sub>             | 11 <sup>1</sup> / <sub>8</sub> | 2                             | 1 <sup>3</sup> / <sub>16</sub> | 6–16d                             | —                                   | —  | 1,540   |
|               | JB214     | 1 <sup>9</sup> / <sub>16</sub>             | 13 <sup>1</sup> / <sub>8</sub> | 2                             | 1 <sup>1</sup> / <sub>4</sub>  | 6–16d                             | 2–10dx1 <sup>1</sup> / <sub>2</sub> | 235  | 1,505   |
| LB            | LB26      | 1 <sup>9</sup> / <sub>16</sub>             | 5 <sup>3</sup> / <sub>8</sub>  | 1 <sup>1</sup> / <sub>2</sub> | 1 <sup>1</sup> / <sub>2</sub>  | 4–16d                             | 2–10dx1 <sup>1</sup> / <sub>2</sub> | 240  | 1,380   |
|               | LB28      | 1 <sup>9</sup> / <sub>16</sub>             | 7 <sup>1</sup> / <sub>4</sub>  | 1 <sup>1</sup> / <sub>2</sub> | 1 <sup>1</sup> / <sub>2</sub>  | 4–16d                             | 2–10dx1 <sup>1</sup> / <sub>2</sub> | 240  | 1,270   |
|               | LB210     | 1 <sup>9</sup> / <sub>16</sub>             | 9 <sup>1</sup> / <sub>4</sub>  | 2                             | 1 <sup>1</sup> / <sub>2</sub>  | 4–16d                             | 2–10dx1 <sup>1</sup> / <sub>2</sub> | 240  | 1,525   |
|               | LB212     | 1 <sup>9</sup> / <sub>16</sub>             | 11 <sup>1</sup> / <sub>8</sub> | 2                             | 1 <sup>1</sup> / <sub>2</sub>  | 4–16d                             | 2–10dx1 <sup>1</sup> / <sub>2</sub> | 240  | 1,580   |
|               | LB214     | 1 <sup>9</sup> / <sub>16</sub>             | 13 <sup>1</sup> / <sub>8</sub> | 2                             | 1 <sup>1</sup> / <sub>2</sub>  | 4–16d                             | 2–10dx1 <sup>1</sup> / <sub>2</sub> | 240  | 1,450   |
|               | LB216     | 1 <sup>9</sup> / <sub>16</sub>             | 15 <sup>1</sup> / <sub>8</sub> | 2                             | 1 <sup>1</sup> / <sub>2</sub>  | 4–16d                             | 2–10dx1 <sup>1</sup> / <sub>2</sub> | 240  | 1,425   |

For **SI**: 1 inch = 25.4 mm, 1 lbf = 4.45 N

1. Refer to Figure 1b (this page) for definitions of hanger nomenclature (W, H, B, TF).
2. Tabulated allowable loads must be selected based on duration of load as permitted by the applicable building code.
3. LB Series hangers provide torsional resistance, which is defined as a moment of not less than 75 pounds (334 N) times the depth of the joist at which the lateral movement of the top or bottom of the joist with respect to the vertical position of the joist is 0.125 inch (3.2 mm).
4. The LB hangers are permitted for welded applications to a supporting steel member provided <sup>1</sup>/<sub>8</sub>-inch thick (throat) by 1<sup>1</sup>/<sub>2</sub>-inch long fillet welds are placed along each edge (dimension "TF" in Figure 1b) of each top flange. Welds must conform to the current A.W.S. D1.3 structural welding code for sheet steel. Uplift loads do not apply for welded hangers.
5. The uplift loads have been increased for wind or earthquake loading with no further increase allowed. The allowable uplift loads must be reduced when other load durations govern.

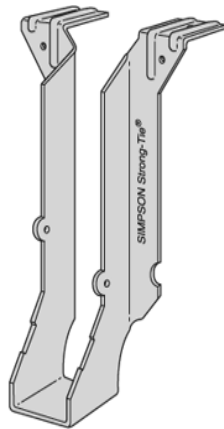

FIGURE 1a—LB HANGER

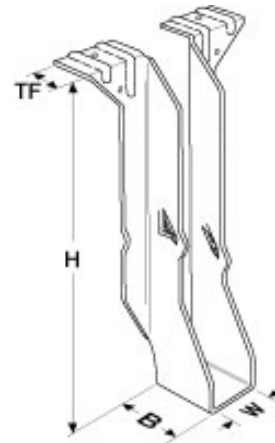

FIGURE 1b—JB HANGER

TABLE 2a—DIMENSIONS OF W, WNP, WNPU, HW, AND HWU SERIES JOIST HANGERS

| HANGER SERIES                 | MODEL NO.                     | DIMENSIONS (in)                |                                | HANGER SERIES                 | MODEL NO.                                     | DIMENSIONS (in)                |   |        |
|-------------------------------|-------------------------------|--------------------------------|--------------------------------|-------------------------------|---|--------------------------------|---|--------|
|                               |                               | (W)                            | (H)                            |                               |   | (W)                            | (H)   |        |
| W                             | W26                           | 1 <sup>9</sup> / <sub>16</sub> | 5 <sup>3</sup> / <sub>8</sub>  | WNPU (cont.)                  | WNPU210-2                                     | 3 <sup>1</sup> / <sub>8</sub>  | 9 <sup>1</sup> / <sub>8</sub>                 |        |
|                               | W28                           |                                | 7 <sup>1</sup> / <sub>8</sub>  |                               | WNPU212-2                                     |                                | 11  |        |
|                               | W210                          |                                | 9 <sup>1</sup> / <sub>8</sub>  |                               | WNPU214-2                                     |                                | 13  |        |
|                               | W212                          |                                | 11                             |                               | WNPU216-2                                     |                                | 15  |        |
|                               | W214                          |                                | 13                             |                               | WNPU412                                       | 11                             |   |        |
|                               | W216                          |                                | 15                             |                               | WNPU414                                       | 13                             |   |        |
|                               | W34                           | 2 <sup>9</sup> / <sub>16</sub> | 3 <sup>7</sup> / <sub>16</sub> |                               | WNPU416                                       | 15                             |   |        |
|                               | W36                           |                                | 5 <sup>3</sup> / <sub>8</sub>  |                               | HW3.25  | 3 <sup>1</sup> / <sub>4</sub>  | 5 (min), 19 <sup>1</sup> / <sub>2</sub> (max) |        |
|                               | W38                           |                                | 7 <sup>1</sup> / <sub>8</sub>  |                               | HW46  | 3 <sup>9</sup> / <sub>16</sub> | 5 <sup>3</sup> / <sub>8</sub>                 |        |
|                               | W310                          | 9 <sup>1</sup> / <sub>8</sub>  | HW48                           |                               | 7 <sup>1</sup> / <sub>8</sub>                 |                                |   |        |
|                               | W44                           | 3 <sup>9</sup> / <sub>16</sub> | 3 <sup>7</sup> / <sub>16</sub> |                               | HW410   |                                | 9 <sup>1</sup> / <sub>8</sub>                 |        |
|                               | W46                           |                                | 5 <sup>3</sup> / <sub>8</sub>  |                               | HW412   |                                | 11  |        |
|                               | W48                           |                                | 7 <sup>1</sup> / <sub>8</sub>  |                               | HW414   |                                | 13  |        |
|                               | W410                          |                                | 9 <sup>1</sup> / <sub>8</sub>  |                               | HW416   |                                | 15  |        |
| 9 <sup>1</sup> / <sub>8</sub> |                               |                                | HW5.25                         | 5 <sup>1</sup> / <sub>4</sub> | 5 (min), 19 <sup>1</sup> / <sub>2</sub> (max) |                                |   |        |
| WNP                           | WNP312                        | 2 <sup>9</sup> / <sub>16</sub> | 11                             | HW                            | HW66  | 5 <sup>1</sup> / <sub>2</sub>  | 5 <sup>3</sup> / <sub>8</sub>                 |        |
|                               | WNP314                        |                                | 13                             |                               | HW68  |                                | 7 <sup>1</sup> / <sub>8</sub>                 |        |
|                               | WNP316                        |                                | 15                             |                               | HW610   |                                | 9 <sup>1</sup> / <sub>8</sub>                 |        |
|                               | WNP26-2                       | 3 <sup>1</sup> / <sub>8</sub>  | 5 <sup>3</sup> / <sub>8</sub>  |                               | HW612   |                                | 11  |        |
|                               | WNP28-2                       |                                | 7 <sup>1</sup> / <sub>8</sub>  |                               | HW614   |                                | 13  |        |
|                               | WNP210-2                      |                                | 9 <sup>1</sup> / <sub>8</sub>  |                               | HW616   |                                | 15  |        |
|                               | WNP212-2                      |                                | 11                             |                               | HW86  | 5 <sup>3</sup> / <sub>8</sub>  |   |        |
|                               | WNP214-2                      |                                | 13                             |                               | HW88  | 7 <sup>1</sup> / <sub>8</sub>  |   |        |
|                               | WNP216-2                      | 15                             | 7 <sup>1</sup> / <sub>2</sub>  |                               | HW810   | 9 <sup>1</sup> / <sub>8</sub>  |   |        |
|                               | WNP412                        | 3 <sup>9</sup> / <sub>16</sub> |                                |                               | 11  | HW812                          | 11  |        |
|                               | WNP414                        |                                |                                |                               | 13  | HW814                          | 13  |        |
|                               | WNP416                        |                                |                                |                               | 15  | HW816                          | 15  |        |
|                               | WNP66                         | 5 <sup>1</sup> / <sub>2</sub>  |                                |                               | 5 <sup>3</sup> / <sub>8</sub>                 | HWU                            | 3 <sup>9</sup> / <sub>16</sub>                | HWU410 |
|                               | WNP68                         |                                | 7 <sup>1</sup> / <sub>8</sub>  |                               | HWU412  |                                |   | 11     |
| WNP610                        | 9 <sup>1</sup> / <sub>8</sub> |                                | HWU414                         | 13                            |   |                                |   |        |
| WNP610                        | 9 <sup>1</sup> / <sub>8</sub> |                                | HWU416                         | 15                            |   |                                |   |        |
| WNPU                          | WNPU312                       | 2 <sup>9</sup> / <sub>16</sub> | 11                             |                               |   |                                |   |        |
|                               | WNPU314                       |                                | 13                             |                               |   |                                |   |        |
|                               | WNPU316                       |                                | 15                             |                               |   |                                |   |        |

For SI: 1 inch = 25.4 mm

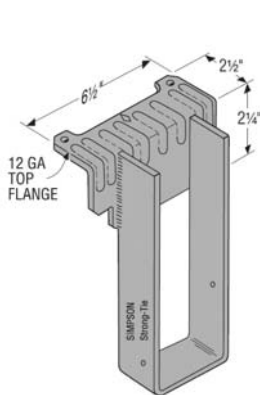

FIGURE 2a—W HANGER SERIES

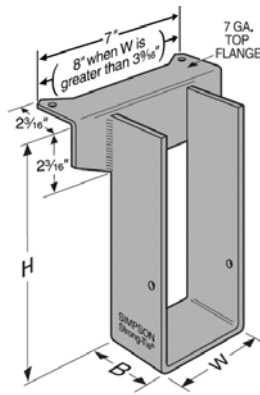

FIGURE 2b—WNP HANGER SERIES

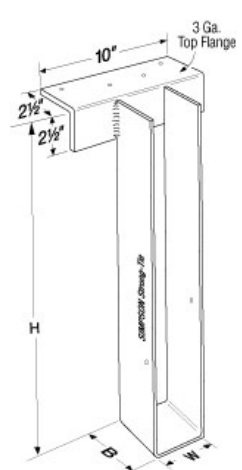

FIGURE 2c—HW AND HWU HANGER SERIES

**TABLE 2b—ALLOWABLE LOADS FOR THE W, WNP, WNPU, HW, AND HWU SERIES JOIST HANGERS**

| HANGER SERIES | HANGER DIMENSIONS <sup>1</sup><br>(inches)                                 |   |                               | FASTENERS<br>(Quantity – Size) |                                    | ALLOWABLE LOAD <sup>2,3</sup><br>(lbs)                                   |  |
|---------------|--|---|-------------------------------|--------------------------------|------------------------------------|--|--|
|               | (W)  | (H)   | (B)                           | Header                         | Joist                              | Uplift <sup>4</sup><br>C <sub>D</sub> =1.33<br>or<br>C <sub>D</sub> =1.6 | Download<br>C <sub>D</sub> = 1.0,<br>C <sub>D</sub> = 1.15,<br>C <sub>D</sub> = 1.25 |
| W             | 1 <sup>9</sup> / <sub>16</sub>   | 5 <sup>3</sup> / <sub>8</sub> (min), 15 (max)                             | 2 <sup>1</sup> / <sub>2</sub> | 2-10d                          | 2-10dx <sup>1</sup> / <sub>2</sub> | —  | 2,200  |
|               | 2 <sup>9</sup> / <sub>16</sub> (min), 3 <sup>9</sup> / <sub>16</sub> (max) | 3 <sup>7</sup> / <sub>16</sub> (min), 9 <sup>1</sup> / <sub>8</sub> (max) | 2                             | 2-10d                          | 2-10dx <sup>1</sup> / <sub>2</sub> | —  | 2,200  |
| WNP           | 2 <sup>9</sup> / <sub>16</sub>   | 11 (min), 15 (max)  | 2 <sup>1</sup> / <sub>2</sub> | 2-10d                          | 2-10dx <sup>1</sup> / <sub>2</sub> | —  | 3,255  |
|               | 3 <sup>1</sup> / <sub>8</sub>  | 5 <sup>3</sup> / <sub>8</sub> (min), 15 (max)                             | 2 <sup>1</sup> / <sub>2</sub> | 2-10d                          | 2-10dx <sup>1</sup> / <sub>2</sub> | —  | 3,255  |
| WNPU          | 3 <sup>9</sup> / <sub>16</sub> (min), 5 <sup>1</sup> / <sub>2</sub> (max)  | 5 <sup>3</sup> / <sub>8</sub> (min), 15 (max)                             | 2 <sup>1</sup> / <sub>2</sub> | 2-10d                          | 2-10dx <sup>1</sup> / <sub>2</sub> | —  | 3,255  |
|               | 2 <sup>9</sup> / <sub>16</sub>   | 11 (min), 15 (max)  | 3                             | 7-16d                          | 6-10dx <sup>1</sup> / <sub>2</sub> | —  | 4,165  |
|               | 3 <sup>1</sup> / <sub>8</sub> (min), 3 <sup>9</sup> / <sub>16</sub> (max)  | 9 <sup>1</sup> / <sub>8</sub> (min), 15 (max)                             | 3                             | 7-16d                          | 6-10d                              | —  | 4,165  |
| HW3.25        | 3 <sup>1</sup> / <sub>4</sub>  | 5 (min), 19 <sup>1</sup> / <sub>2</sub> (max)                             | 4                             | 4-10d                          | 2-10d                              | —  | 5,285  |
| HW5.25        | 5 <sup>1</sup> / <sub>4</sub>  | 5 (min), 19 <sup>1</sup> / <sub>2</sub> (max)                             | 2 <sup>1</sup> / <sub>2</sub> | 4-10d                          | 2-10d                              | —  | 5,285  |
| HW            | 3 <sup>9</sup> / <sub>16</sub>   | 5 <sup>3</sup> / <sub>8</sub> (min), 15 (max)                             | 2 <sup>1</sup> / <sub>2</sub> | 4-10d                          | 2-10d                              | —  | 5,285  |
|               | 5 <sup>1</sup> / <sub>2</sub> (min), 7 <sup>1</sup> / <sub>2</sub> (max)   | 5 <sup>3</sup> / <sub>8</sub> (min), 15 (max)                             | 2 <sup>1</sup> / <sub>2</sub> | 4-10d                          | 2-10d                              | —  | 5,285  |
| HWU           | 3 <sup>9</sup> / <sub>16</sub>   | 9 <sup>1</sup> / <sub>8</sub> (min), 15 (max)                             | 3 <sup>1</sup> / <sub>4</sub> | 8-16d                          | 6-10d                              | —  | 6,335  |

For SI: 1 inch = 25.4 mm, 1 lbs = 4.45 N

1. Refer to Figure 2b (previous page) for definitions of hanger nomenclature (W, H, B).
2. Hangers may be welded to steel headers with weld size to match hanger flange material thickness (approximate thickness shown in Section 3.2.1 of this report).  
 W hanger series: The throat size of the fillet weld must be <sup>3</sup>/<sub>16</sub>-inch thick.  
 WNP hanger series: The throat size of the fillet weld must be <sup>1</sup>/<sub>8</sub>-inch thick.  
 WNPU, HW, and HWU hanger series: The throat size of the fillet weld must be <sup>1</sup>/<sub>4</sub>-inch thick.  
 The length of the weld at each flange must be at least 1<sup>1</sup>/<sub>2</sub> inches long. Welds must conform to the current A.W.S. D1.3 structural welding code for sheet steel, and the weld material must be E-70S.
3. The connectors provide a torsional resistance up to a maximum joist depth of 16 inches for the W, WNP, and WNPU hangers and 22 inches for the HW and HWU hangers, where torsional resistance is defined as a moment of not less than 75 pounds (334 N) times the depth of the joist at which the lateral movement of the top or bottom of the joist with respect to the vertical position of the joist is 0.125 inch (3.2 mm).
4. Uplift loads for these hangers are beyond the scope of this report.

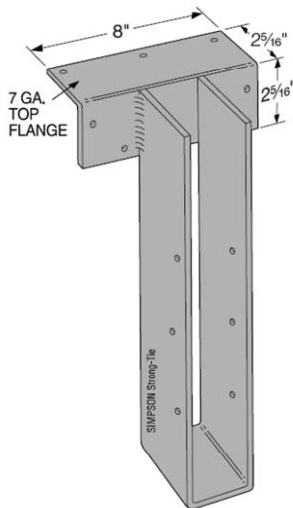

**FIGURE 2d—WNPU HANGER SERIES**

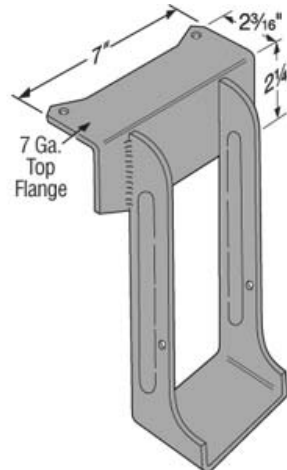

**FIGURE 2e—WNP412, WNP414, and WNP416 HANGERS**

TABLE 3—ALLOWABLE LOADS FOR THE HUTF SERIES JOIST HANGERS

| MODEL NO. | HANGER DIMENSIONS <sup>1</sup><br>(in) |                                |                               |                               | FASTENERS<br>(Quantity–Size) |                                     | ALLOWABLE LOADS <sup>2,3,4</sup>                 |                      |                       |                       |
|-----------|--|--------------------------------|-------------------------------|-------------------------------|------------------------------|-------------------------------------|--|----------------------|-----------------------|-----------------------|
|           | W                                      | H                              | B                             | TF                            | Header                       | Joist                               | Uplift <sup>5</sup>                              | Download             |                       |                       |
|           |  |                                |                               |                               |                              |                                     | C <sub>D</sub> = 1.33 or<br>C <sub>D</sub> = 1.6 | C <sub>D</sub> = 1.0 | C <sub>D</sub> = 1.15 | C <sub>D</sub> = 1.25 |
| HU24TF    | 1 <sup>9</sup> / <sub>16</sub>         | 3 <sup>7</sup> / <sub>16</sub> | 2 <sup>1</sup> / <sub>4</sub> | 2 <sup>1</sup> / <sub>2</sub> | 6–16d                        | 2–10dx1 <sup>1</sup> / <sub>2</sub> | 245  | 2,060                | 2,085                 | 2,100                 |
| HU26TF    |  | 5 <sup>3</sup> / <sub>8</sub>  |                               |                               | 10–16d                       | 4–10dx1 <sup>1</sup> / <sub>2</sub> | 490  | 2,245                | 2,300                 | 2,335                 |
| HU28TF    |  | 7 <sup>1</sup> / <sub>8</sub>  |                               |                               | 10–16d                       | 4–10dx1 <sup>1</sup> / <sub>2</sub> | 490  | 2,245                | 2,300                 | 2,335                 |
| HU210TF   |  | 9 <sup>1</sup> / <sub>8</sub>  |                               |                               | 12–16d                       | 4–10dx1 <sup>1</sup> / <sub>2</sub> | 490  | 2,245                | 2,300                 | 2,335                 |
| HU212TF   |  | 11                             |                               |                               | 14–16d                       | 6–10dx1 <sup>1</sup> / <sub>2</sub> | 735  | 2,335                | 2,335                 | 2,335                 |
| HU214TF   |  | 13                             |                               |                               | 16–16d                       | 6–10dx1 <sup>1</sup> / <sub>2</sub> | 735  | 2,425                | 2,510                 | 2,565                 |
| HU216TF   |  | 15                             |                               |                               | 18–16d                       | 8–10dx1 <sup>1</sup> / <sub>2</sub> | 980  | 2,610                | 2,720                 | 2,795                 |
| HU34TF    | 2 <sup>9</sup> / <sub>16</sub>         | 3 <sup>7</sup> / <sub>16</sub> | 2 <sup>1</sup> / <sub>2</sub> | 2 <sup>1</sup> / <sub>2</sub> | 8–16d                        | 2–10dx1 <sup>1</sup> / <sub>2</sub> | 245  | 2,600                | 2,600                 | 2,600                 |
| HU36TF    |  | 5 <sup>3</sup> / <sub>8</sub>  |                               |                               | 10–16d                       | 4–10dx1 <sup>1</sup> / <sub>2</sub> | 490  | 3,495                | 3,550                 | 3,585                 |
| HU38TF    |  | 7 <sup>1</sup> / <sub>8</sub>  |                               |                               | 12–16d                       | 4–10dx1 <sup>1</sup> / <sub>2</sub> | 490  | 3,495                | 3,550                 | 3,585                 |
| HU310TF   |  | 9 <sup>1</sup> / <sub>8</sub>  |                               |                               | 14–16d                       | 6–10dx1 <sup>1</sup> / <sub>2</sub> | 735  | 3,675                | 3,760                 | 3,815                 |
| HU312TF   |  | 11                             |                               |                               | 16–16d                       | 6–10dx1 <sup>1</sup> / <sub>2</sub> | 735  | 3,675                | 3,760                 | 3,815                 |
| HU314TF   |  | 13                             |                               |                               | 18–16d                       | 6–10dx1 <sup>1</sup> / <sub>2</sub> | 980  | 4,335                | 4,335                 | 4,335                 |
| HU316TF   |  | 15                             |                               |                               | 20–16d                       | 8–10dx1 <sup>1</sup> / <sub>2</sub> | 980  | 3,860                | 3,970                 | 4,045                 |
| HU24-2TF  | 3 <sup>1</sup> / <sub>8</sub>          | 3 <sup>7</sup> / <sub>16</sub> | 2 <sup>1</sup> / <sub>2</sub> | 2 <sup>1</sup> / <sub>2</sub> | 8–16d                        | 2–10d                               | 310  | 2,600                | 2,600                 | 2,600                 |
| HU26-2TF  |  | 5 <sup>3</sup> / <sub>8</sub>  |                               |                               | 10–16d                       | 4–16d                               | 625  | 3,730                | 3,855                 | 3,900                 |
| HU28-2TF  |  | 7 <sup>1</sup> / <sub>8</sub>  |                               |                               | 12–16d                       | 4–16d                               | 625  | 3,900                | 3,900                 | 3,900                 |
| HU210-2TF |  | 9 <sup>1</sup> / <sub>8</sub>  |                               |                               | 14–16d                       | 6–16d                               | 935  | 4,170                | 4,170                 | 4,170                 |
| HU212-2TF |  | 11                             |                               |                               | 16–16d                       | 6–16d                               | 935  | 4,335                | 4,335                 | 4,335                 |
| HU214-2TF |  | 13                             |                               |                               | 18–16d                       | 8–16d                               | 1,250  | 4,335                | 4,335                 | 4,335                 |
| HU216-2TF |  | 15                             |                               |                               | 20–16d                       | 8–16d                               | 1,250  | 4,335                | 4,335                 | 4,335                 |
| HU44TF    | 3 <sup>9</sup> / <sub>16</sub>         | 3 <sup>7</sup> / <sub>16</sub> | 2 <sup>1</sup> / <sub>2</sub> | 2 <sup>1</sup> / <sub>2</sub> | 8–16d                        | 2–10d                               | 310  | 2,600                | 2,600                 | 2,600                 |
| HU46TF    |  | 5 <sup>3</sup> / <sub>8</sub>  |                               |                               | 10–16d                       | 4–16d                               | 625  | 3,165                | 3,165                 | 3,165                 |
| HU48TF    |  | 7 <sup>1</sup> / <sub>8</sub>  |                               |                               | 12–16d                       | 4–16d                               | 625  | 3,500                | 3,500                 | 3,500                 |
| HU410TF   |  | 9 <sup>1</sup> / <sub>8</sub>  |                               |                               | 14–16d                       | 6–16d                               | 935  | 4,150                | 4,150                 | 4,150                 |
| HU412TF   |  | 11                             |                               |                               | 16–16d                       | 6–16d                               | 935  | 4,560                | 4,810                 | 5,110                 |
| HU414TF   |  | 13                             |                               |                               | 18–16d                       | 8–16d                               | 1,250  | 4,835                | 5,050                 | 5,050                 |
| HU416TF   |  | 15                             |                               |                               | 20–16d                       | 8–16d                               | 1,250  | 5,050                | 5,050                 | 5,050                 |
| HU210-3TF | 4 <sup>11</sup> / <sub>16</sub>        | 9 <sup>1</sup> / <sub>8</sub>  | 2 <sup>1</sup> / <sub>2</sub> | 2 <sup>1</sup> / <sub>2</sub> | 14–16d                       | 6–16d                               | 1,105  | 4,150                | 4,150                 | 4,150                 |
| HU212-3TF |  | 11                             |                               |                               | 16–16d                       | 6–16d                               | 1,105  | 4,560                | 4,810                 | 5,110                 |
| HU214-3TF |  | 13                             |                               |                               | 18–16d                       | 8–16d                               | 1,470  | 4,835                | 5,050                 | 5,050                 |
| HU216-3TF |  | 15                             |                               |                               | 20–16d                       | 8–16d                               | 1,470  | 5,050                | 5,050                 | 5,050                 |
| HU66TF    | 5 <sup>1</sup> / <sub>2</sub>          | 5 <sup>3</sup> / <sub>8</sub>  | 2 <sup>1</sup> / <sub>2</sub> | 2 <sup>1</sup> / <sub>2</sub> | 10–16d                       | 4–16d                               | 735  | 3,165                | 3,165                 | 3,165                 |
| HU68TF    |  | 7 <sup>1</sup> / <sub>8</sub>  |                               |                               | 12–16d                       | 4–16d                               | 735  | 3,500                | 3,500                 | 3,500                 |
| HU610TF   |  | 9 <sup>1</sup> / <sub>8</sub>  |                               |                               | 14–16d                       | 6–16d                               | 1,105  | 4,150                | 4,150                 | 4,150                 |
| HU612TF   |  | 11                             |                               |                               | 16–16d                       | 6–16d                               | 1,105  | 4,550                | 4,810                 | 5,105                 |
| HU614TF   |  | 13                             |                               |                               | 18–16d                       | 8–16d                               | 1,470  | 4,830                | 5,125                 | 5,450                 |
| HU616TF   |  | 15                             |                               |                               | 20–16d                       | 8–16d                               | 1,470  | 5,105                | 5,445                 | 5,795                 |

For SI: 1 inch = 25.4 mm, 1 pound = 4.45 N.

1. Refer to Figure 3a (next page) for definitions of hanger nomenclature (W, H, B, TF).
2. Tabulated allowable loads must be selected based on duration of load as permitted by the applicable building code.
3. The minimum wood header or ledger size that can be used with HUTF hangers is 3<sup>1</sup>/<sub>2</sub> inches. See Figure 3b (next page).
4. The hanger provides a torsional resistance up to a maximum joist depth of 16<sup>1</sup>/<sub>2</sub> inches, where torsional resistance is defined as a moment of not less than 75 pounds (334 N) times the depth of the joist at which the lateral movement of the top or bottom of the joist with respect to the vertical position of the joist is 0.125 inch (3.2 mm).
5. Tabulated allowable uplift loads have been increased for wind or earthquake loading with no further increase allowed. The allowable uplift loads must be reduced when other load durations govern.

**TABLE 4—ALLOWABLE LOADS FOR THE HUSTF SERIES JOIST HANGERS**

| MODEL NO.  | DIMENSIONS <sup>1</sup><br>(inches) |                                |   |                                | FASTENERS<br>(Quantity – Size) |                    | ALLOWABLE LOADS <sup>2,3</sup><br>(lbs)          |                      |                       |                       |
|------------|-------------------------------------|--------------------------------|---|--------------------------------|--------------------------------|--------------------|--|----------------------|-----------------------|-----------------------|
|            | W                                   | H                              | B | TF                             | Header                         | Joist <sup>4</sup> | Uplif <sup>5</sup>                               | Download             |                       |                       |
|            |                                     |                                |   |                                |                                |                    | C <sub>D</sub> = 1.33 or<br>C <sub>D</sub> = 1.6 | C <sub>D</sub> = 1.0 | C <sub>D</sub> = 1.15 | C <sub>D</sub> = 1.25 |
| HUS26-2TF  | 3 <sup>1</sup> / <sub>8</sub>       | 5 <sup>3</sup> / <sub>8</sub>  | 2 | 1 <sup>3</sup> / <sub>4</sub>  | 6–16d                          | 4–16d              | 1,080  | 2,820                | 3,000                 | 3,000                 |
| HUS28-2TF  | 3 <sup>1</sup> / <sub>8</sub>       | 7 <sup>1</sup> / <sub>4</sub>  | 2 | 1 <sup>3</sup> / <sub>8</sub>  | 8–16d                          | 6–16d              | 1,550  | 3,455                | 3,720                 | 3,895                 |
| HUS210-2TF | 3 <sup>1</sup> / <sub>8</sub>       | 9 <sup>1</sup> / <sub>4</sub>  | 2 | 1 <sup>1</sup> / <sub>2</sub>  | 10–16d                         | 8–16d              | 2,160  | 3,585                | 3,925                 | 4,155                 |
| HUS212-2TF | 3 <sup>1</sup> / <sub>8</sub>       | 11 <sup>1</sup> / <sub>8</sub> | 2 | 2 <sup>1</sup> / <sub>4</sub>  | 10–16d                         | 8–16d              | 2,000  | 4,435                | 4,535                 | 4,605                 |
| HUS214-2TF | 3 <sup>1</sup> / <sub>8</sub>       | 13 <sup>1</sup> / <sub>8</sub> | 2 | 2 <sup>1</sup> / <sub>4</sub>  | 12–16d                         | 8–16d              | 2,160  | 4,435                | 4,535                 | 4,605                 |
| HUS46TF    | 3 <sup>9</sup> / <sub>16</sub>      | 5 <sup>3</sup> / <sub>8</sub>  | 2 | 1 <sup>9</sup> / <sub>16</sub> | 6–16d                          | 4–16d              | 1,080  | 2,700                | 2,890                 | 3,000                 |
| HUS48TF    | 3 <sup>9</sup> / <sub>16</sub>      | 7 <sup>1</sup> / <sub>4</sub>  | 2 | 1 <sup>9</sup> / <sub>16</sub> | 8–16d                          | 6–16d              | 1,550  | 3,225                | 3,495                 | 3,670                 |
| HUS410TF   | 3 <sup>9</sup> / <sub>16</sub>      | 9 <sup>1</sup> / <sub>4</sub>  | 2 | 1 <sup>1</sup> / <sub>4</sub>  | 10–16d                         | 8–16d              | 2,160  | 3,365                | 3,710                 | 3,935                 |
| HUS412TF   | 3 <sup>9</sup> / <sub>16</sub>      | 11 <sup>1</sup> / <sub>8</sub> | 2 | 2 <sup>1</sup> / <sub>16</sub> | 10–16d                         | 8–16d              | 2,000  | 4,420                | 4,760                 | 4,990                 |
| HUS414TF   | 3 <sup>9</sup> / <sub>16</sub>      | 13 <sup>1</sup> / <sub>8</sub> | 2 | 2 <sup>1</sup> / <sub>16</sub> | 12–16d                         | 8–16d              | 2,160  | 4,765                | 5,100                 | 5,100                 |

For SI: 1 lb = 4.45 N, 1 inch = 25.4 mm

1. Refer to Figure 4a (this page) for definitions of hanger nomenclature (W, H, B, TF).
2. Tabulated allowable load capacities must be selected based on duration of load as permitted by the applicable building code.
3. The HUSTF Series hangers provide torsional resistance, which is defined as a moment of not less than 75 pounds (334 N) times the depth of the joist at which the lateral movement of the top or bottom of the joist with respect to the vertical position of the joist is 0.125 inch (3.2 mm).
4. The U-shaped portion of the hangers have pre-punched holes for the installation of joist that are driven at a 45-degree angle through the joist and into the header, which is described as double shear nailing in the installation instructions. See Figure 4b (this page).
5. The uplift loads have been increased for wind or earthquake loading with no further increase allowed. The allowable uplift loads must be reduced when other load durations govern.

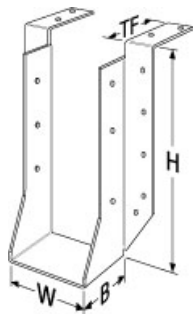

**FIGURE 3a—HUTF HANGER SERIES**  
(See Table 3)

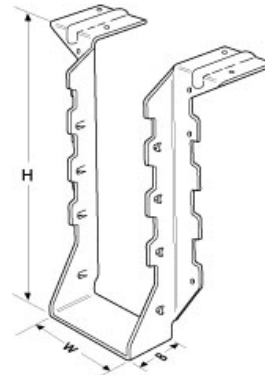

**FIGURE 4a—HUSTF HANGER SERIES**  
(See Table 4)

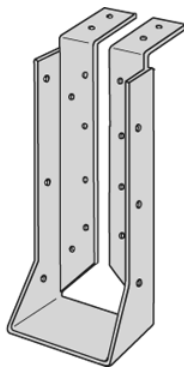

**FIGURE 3b—HUTF HANGER (with concealed flanges)**  
(See Table 3)

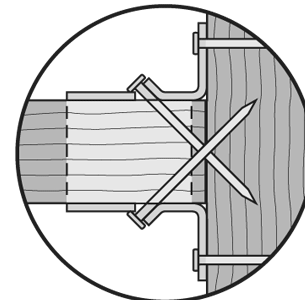

**FIGURE 4b—TOP VIEW OF DOUBLE SHEAR NAILING**  
REQUIRED FOR HUSTF HANGERS (See Footnote 4, Table 4)

TABLE 5—ALLOWABLE LOADS FOR THE PF/PFA/PFD SERIES JOIST HANGERS

| MODEL NO. | DIMENSIONS <sup>1</sup><br>(inches) |                                |                               |                                |                                | FASTENERS<br>(Quantity–Size) |                    | ALLOWABLE LOADS <sup>2,3</sup><br>(lbs)             |       |       |                      |
|-----------|-------------------------------------|--------------------------------|-------------------------------|--------------------------------|--------------------------------|------------------------------|--------------------|---|-------|-------|----------------------|
|           | W                                   | H                              | B                             | TF                             | S                              | Header                       | Joist <sup>4</sup> | Uplift <sup>5</sup>                                 |       |       |                      |
|           |                                     |                                |                               |                                |                                |                              |                    | C <sub>D</sub> = 1.33<br>or<br>C <sub>D</sub> = 1.6 |       |       | C <sub>D</sub> = 1.0 |
| PF24      | 1 <sup>9</sup> / <sub>16</sub>      | 5 <sup>3</sup> / <sub>8</sub>  | 1 <sup>1</sup> / <sub>2</sub> | 1 <sup>1</sup> / <sub>16</sub> | —                              | 2–10d                        | 2–10d              | 260   | 955   | 955   | 955                  |
| PF26      | 1 <sup>9</sup> / <sub>16</sub>      | 5 <sup>9</sup> / <sub>16</sub> | 1 <sup>1</sup> / <sub>2</sub> | 1 <sup>1</sup> / <sub>16</sub> | —                              | 2–10d                        | 2–10d              | 260   | 955   | 955   | 955                  |
| PFD24     | 1 <sup>9</sup> / <sub>16</sub>      | 3 <sup>1</sup> / <sub>2</sub>  | 1 <sup>1</sup> / <sub>4</sub> | —                              | 1 <sup>9</sup> / <sub>16</sub> | —                            | 2–10d              | 235   | 910   | 935   | 955                  |
| PFD26     | 1 <sup>9</sup> / <sub>16</sub>      | 5 <sup>1</sup> / <sub>2</sub>  | 1 <sup>1</sup> / <sub>4</sub> | —                              | 1 <sup>9</sup> / <sub>16</sub> | —                            | 4–10d              | 470   | 1,085 | 1,140 | 1,175                |
| PFDS26    | 1 <sup>9</sup> / <sub>16</sub>      | 5 <sup>1</sup> / <sub>2</sub>  | 1 <sup>1</sup> / <sub>4</sub> | —                              | 3 <sup>1</sup> / <sub>4</sub>  | 4–10d                        | 4–10d              | 520   | 1,045 | 1,090 | 1,120                |
| PF24A     | 1 <sup>9</sup> / <sub>16</sub>      | 3 <sup>1</sup> / <sub>2</sub>  | 1 <sup>1</sup> / <sub>4</sub> | 1 <sup>1</sup> / <sub>2</sub>  | —                              | 2–10d                        | 2–10d              | 235   | 800   | 800   | 800                  |
| PF26A     | 1 <sup>9</sup> / <sub>16</sub>      | 5 <sup>1</sup> / <sub>2</sub>  | 1 <sup>1</sup> / <sub>4</sub> | 1 <sup>1</sup> / <sub>2</sub>  | —                              | 2–10d                        | 4–10d              | 520   | 1,045 | 1,090 | 1,120                |

For **SI**: 1 inch = 25.4 mm, 1 pound = 4.45 N

1. Refer to Figures 5a and 5c (this page) for definitions of PF and PFA hanger nomenclature (W, H, B, TF). Refer to Figures 5b (this page) for definitions of PFD hanger nomenclature (W, H, B, S).
2. Tabulated allowable load capacities must be selected based on duration of load as permitted by the applicable building code.
3. The connectors provide a torsional resistance up to a maximum joist depth of 5<sup>1</sup>/<sub>2</sub> inches, where torsional resistance is defined as a moment of not less than 75 pounds (334 N) times the depth of the joist at which the lateral movement of the top or bottom of the joist with respect to the vertical position of the joist is 0.125 inch (3.2 mm).
4. The U-shaped portion of the hangers have pre-punched holes for the installation of nails that are driven at a 45-degree angle through the joist and into the header, which is described as double shear nailing in the installation instructions. See Figure 5d (this page).
5. The uplift loads have been increased for wind or earthquake loading with no further increase is allowed. The allowable uplift loads must be reduced when other load durations govern.

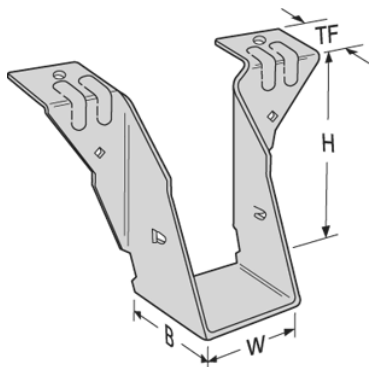

FIGURE 5a—PF24 and PF26 HANGERS

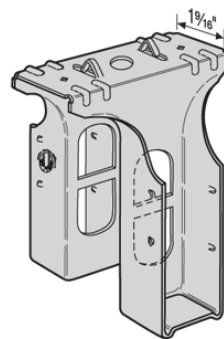

FIGURE 5b—PFD24, PFD26, and PFDS26 HANGERS

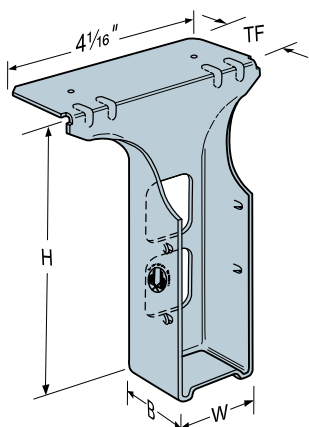

FIGURE 5c—PF24A AND PF26A HANGERS

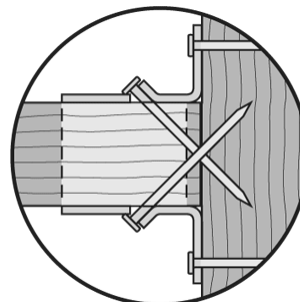

FIGURE 5d—TOP VIEW OF DOUBLE SHEAR NAILING REQUIRED FOR PF/PFA/PFD HANGERS (See Footnote 4, Table 5)

TABLE 6—ALLOWABLE LOADS FOR THE RR RIDGE RAFTER CONNECTOR

| MODEL NO. | FASTENERS<br>(Quantity – Size) |          | ALLOWABLE LOADS <sup>1,2</sup><br>(lbs) |                       |                       |
|-----------|--------------------------------|----------|---|-----------------------|-----------------------|
|           | Header                         | Joist    | C <sub>D</sub> = 1.0                    | C <sub>D</sub> = 1.15 | C <sub>D</sub> = 1.25 |
| RR        | 4-10dx1½                       | 4-10dx1½ | 365                                     | 415                   | 415                   |

For SI: 1 inch = 25.4 mm, 1 pound = 4.45 N

1. The connector may be used with a rafter slope up to 30 degrees maximum.
2. RR hangers provide a torsional resistance up to a maximum joist depth of 13½ inches, where torsional resistance is defined as a moment of not less than 75 pounds (334 N) times the depth of the joist at which the lateral movement of the top or bottom of the joist with respect to the vertical position of the joist is 0.125 inch (3.2 mm).
3. Tabulated allowable loads must be selected based on duration of load as permitted by the applicable building code.

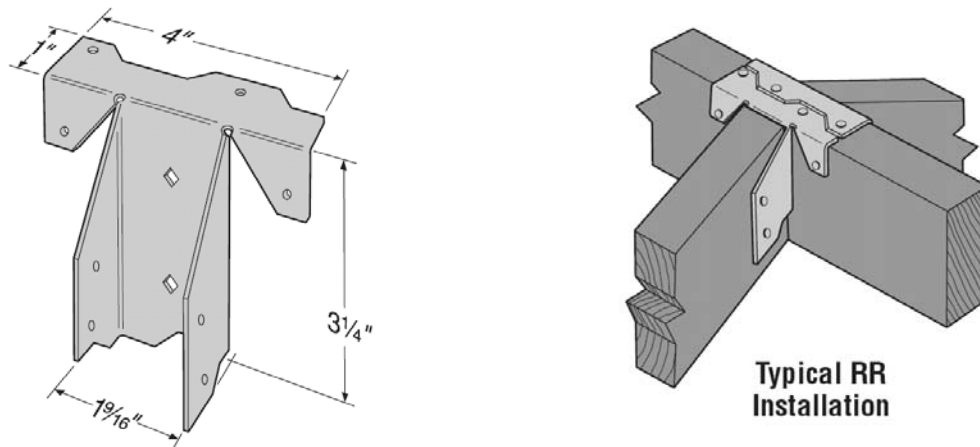

FIGURE 6—RR RIDGE RAFTER CONNECTOR